



# PNEUMATIC COUNTER

## 6-Digit Pneumatic Totalizing Counter



The PT-1SM is a 6-digit pneumatic totalizing counter. A pneumatic signal or impulse adds the value of 1 to the display. When the indicator reaches its maximum value, the counter starts again at zero. The counter may be reset manually by depressing the reset push button, or by an air impulse. The counter is useful for event recording, piece or part counting, for indicating program steps, cycle counting, machine time logging, and many other purposes. The PT-1SM is designed for surface mounting.

**Display:** 6 figures, numerals 0.080" to 0.160"

**Medium:** Filtered compressed air containing no oil

**Reset:** Manual push button and pneumatic spring return

**Input Pressure:** 30 to 120 psig

**Mounting:** Surface mount

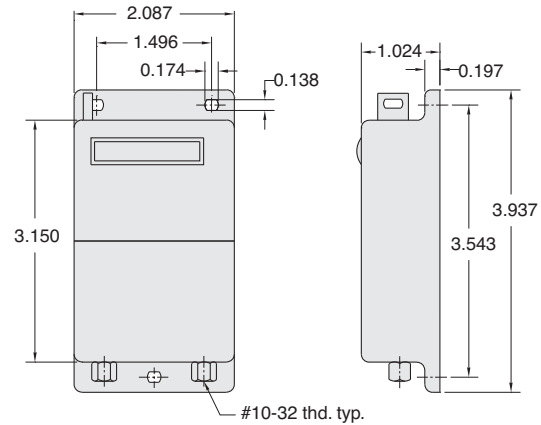

Part No.	Description
PT-1SM	6-Digit Pneumatic Totalizing Counter

## Pneumatic Counter Solutions

Pneumatic counters are used in a variety of pneumatic applications including filling machines, cut counting, stamping, multi-spindle operations and more. They count pulses generated by cylinders, push buttons, pedals, and other actuation devices.

Clippard's 6-digit totalizing counter can be found in many places throughout their manufacturing operations.

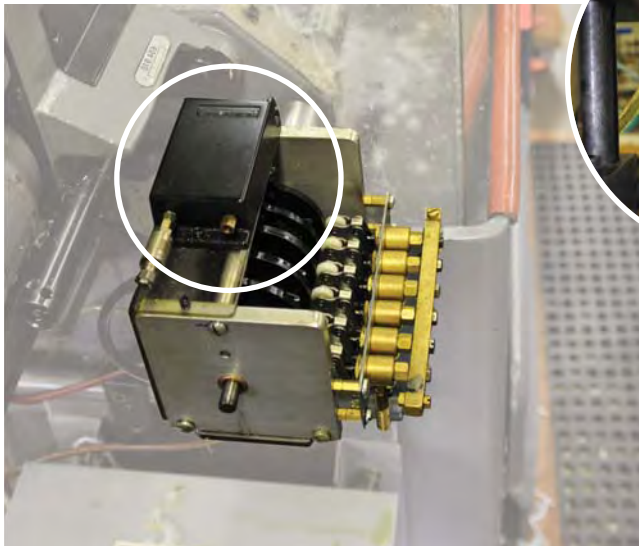

4-Spindle Turret Operation

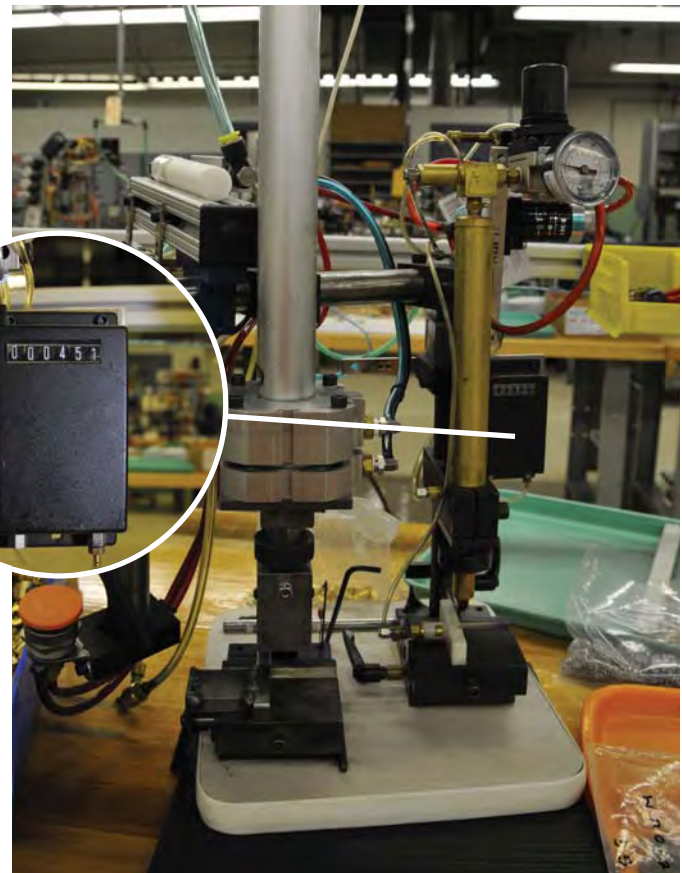

Date Stamping Operation

Metric line available. Visit [www.clippard.com](http://www.clippard.com)