

High Pressure Single Stage Blowdown Valve Type EKINx11

The EKINx11 Angle Pattern Blowdown Valve is designed for High Pressure Blowdown service. Typical applications for this valve are Boiler Drum Continuous and Intermittent Blowdown Lines.

The Angle Pattern Blowdown Valve design combines the advantages of high leak tightness of a High Pressure Stop valve and a throttle valve handling high pressure drop, at the same time.

The valve has a slotted and stellited plug which helps to reduce pressure in a Single Stage. The slotted plug or control plug slots are machined as per the flow handled by the valve.

Needle Plug Design is also offered on request.

Due to the unique design of plug, the seating area is separated from the throttling area. This helps protect the seat from effects of Cavitation and flashing and therefore enhances seat life.

The Control plug and Seat are stellited to resist erosion and wear.

The spindle and plug are manufactured from a single bar forging. This feature helps to eliminate high frequency vibration of plug normally associated with a guided plug stem design.

The spindle does not rotate when the hand wheel is operated. Instead the unique yoke bush and stem assembly converts the rotation of handwheel into a linear movement of the stem. The plug therefore never rotates on the valve seat while the valve is being operated. Damage to seat by entrapped solid can be avoided.

High density pure graphite rings and roller burnishing (mirror finish) of Spindle and stuffing box bore, reduce damage to the gland packing rings and helps reduce possible leakage through gland packing.

The Yoke bush is provided with Roller Thrust Bearing for ease of operation with Handwheel.

The Valve can be operated by a hand wheel or with an electrical actuator. Valve construction complies to Indian Boiler Regulation requirements.

Valves offered in Butt Weld, Socket weld end. Flanged end connection are also offered against request.

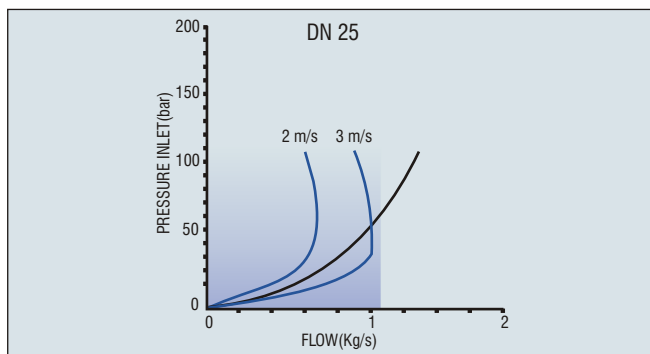

- 1 Working Medium :Boiling water in liquid state at valve inlet.
- 2 Characteristic :Modified Linear (theoretical).Harmful effects of Flashing and cavitation reduced by controlling the velocity at valve seat below 4 m/s .Higher Velocities at valve seat over long duration may cause deterioration of leak tightness at valve seat.
- 3 Application: Feed Water Bypass relief, Sampling System, Drains and other services where manually operated conventional globe valves fail due to erosion at seat when operated in semi open position.

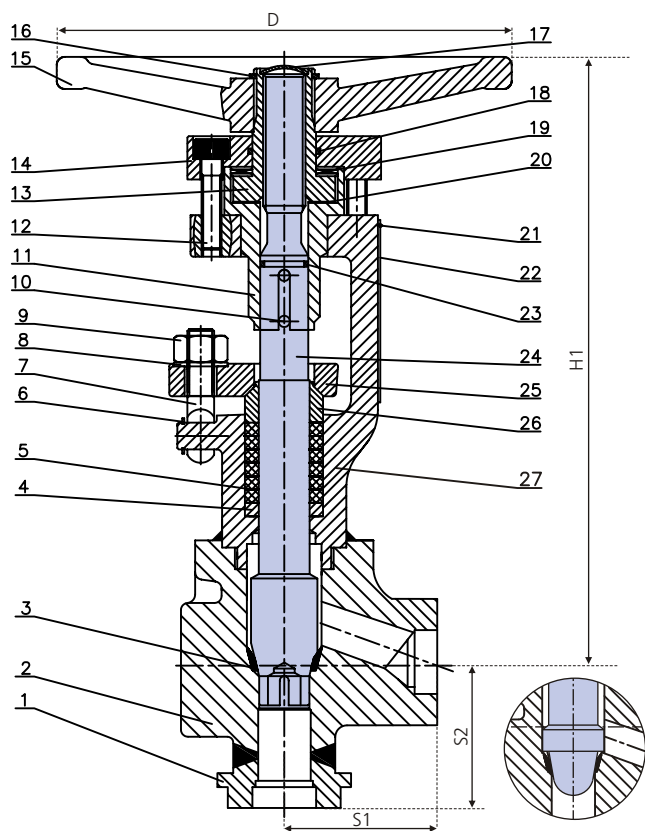

Sl. No.	Description	Qty	Matl Spec.01	Matl.Spec 13
1	Stub End	1	ASTM A 105	ASTM A182 F22
2	Body	1	ASTM A 105	ASTM A182 F22
3	Body Seat	1	Stellite 6	Stellite 6
4	Bottom Ring	1	ASTM A276 Gr.410	ASTM A276 Gr.410
5	Packing	6	Pure Graphite	Pure Graphite
6	Circlip	2	SS	SS
7	Eye Bolt	2	A193 B7	A193 B7
8	Washer	2	C 45	C 45
9	Nut	2	ASTM A193 Gr.2H	ASTM A193 Gr.2H
10	Pin	1	SS 431	SS 431
11	Bush	1	A276 GR 410	A276 GR 410
12	Allen Bolt	4	GR.12.9	GR.12.9
13	Yoke Bush	1	Brass	Brass
14	Cover	1	ASTM A 105	ASTM A 105
15	Handwheel	1	SG Iron	SG Iron
16	Circlip	1	SS	SS
17	Sealing Washer	1	CRCA Sheet	CRCA Sheet
18	O-Ring	1	Viton	Viton
19	Thrust Bearing	1	STD	STD
20	Slide Ring	1	SS	SS
21	Dowel Pin	4	SS	SS
22	Name Plate	2	SS	SS
23	'O'Ring	1	Viton	Viton
24	Spindle	1	SS431	SS431
25	Gland Flange	1	ASTM A 105	ASTM A 105
26	Gland Follower	1	SS 410	SS 410
27	Bonnet	1	ASTM A 105	ASTM A 182 F22

Example for Designation of Blowdown Valve

EKINx11 2500 1" 01 33
 — Standard Accessories
 — Material Specification
 — ANSI Nominal size DN (inch)
 — ANSI Nominal Pressure PN (lbs)
 — Type abbr.

EKINx11 400 25 01 33
 — Standard Accessories
 — Material Specification
 — DIN Nominal Size DN (mm)
 — DIN Nominal Pressure PN (bar)
 — Type abbr.

Note: Selection of accessory is dependent on the application and mode of operation.

DIN		ANSI		DIMENSIONS IN MM				WEIGHT
DN	PN	DN	PN	HI	D	S1	S2	KGS
25	160 250	1"	900 1500	290	170	~65	~65	9
40	160 250	1 1/2"	900 1500	440	170	~110	~110	25
50	160 250	2"	900 1500	440	170	~110	~110	25
80	160 250	3"	900 1500	440	250	~125	~200	78

SN Standardized Accessories

- SN 25 Copper free materials
- SN 33 Valve Yoke with connection acc. ISO 5210 / DIN 3210
- SN 33.4 Valve Yoke with connection acc. ISO 521: for subsequent mounting from actuator
- SN 34 Valve Yoke for Pneumatic Actuator
- SN 41 Plug with Stellite deposition
- SN 43 Material transition rings
- SN 46 Control Plug Slotted Type
- SN 47 Control Plug Parabolic type

		MAXIMUM WORKING PRESSURE KG/CM ²																
Matl. Spec.	Body Matl.	Class	Working Temperature Deg. C															
			93	149	204	260	315	343	371	399	427	454	510	538	593			
01	A105	1500	237	230	223	210	192	188	157	177	144							
		2500	395	384	371	350	320	314	312	295	241							
13	A182 F22	1500			227	225	212	206	199	187	178	171	132	94	39			
		2500			379	374	354	344	332	311	297	285	221	156	55			



www.forbesmarshall.com

Forbes Marshall Pvt. Ltd.
 A-34/35, MIDC, Industrial Estate, 'H' Block, Pimpri, Pune - 411 018. India.
 Tel.: 91(0)20 - 27442020
 Fax: 91(0)20 - 27442040 E-mail: aganorkar@forbesmarshall.com

Domestic:
 Ahmedabad, Alibag, Bangalore, Bhopal / Indore, Chandigarh, Chennai, Coimbatore, Delhi, Hyderabad, Jamshedpur, Kolkata, Mumbai, Nagpur, Navi Mumbai, Surat, Trichy, Vadodara, Visakhapatnam
International Operations: exp@forbesmarshall.com
 Bangladesh, Canada, Egypt, Indonesia, Iran, Kenya, Malaysia, Nepal, Sri Lanka, Thailand, U.A.E. (Instrumentation) (Boilers & Boiler Accessories)USA,



Trusted Partners.
 Innovative Solutions.