

Catalog Power Unit Accessories

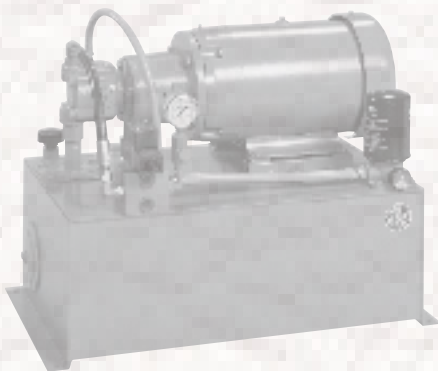

Power Unit Accessories

Features

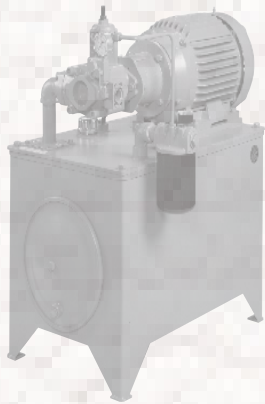
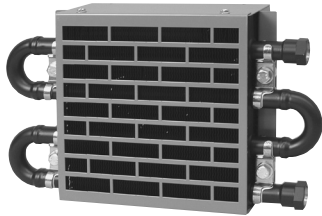

Continental Hydraulics offers a wide range of accessories that can be either mounted on the power unit, or purchased separately. Everything from filters and gauges to gear pumps and electric motors can be found in the Accessories Catalog.

A wide selection of heat exchangers and temperature monitoring devices can be selected to remove excess heat from power units and extend the life of most hydraulic components.



Filters, strainers and magnets help reduce the amount of contamination in the system reducing the wear and tear on pumps and valves.

In-line accessories such as relief valves, ball valves and check valves help finish any plumbing needs required for your system.



A full description and dimensional information can be found for each component as well as flow curves, technical data and part numbers on its given page. If additional information is needed, please call Continental Hydraulics.





Power Unit Accessories

Table of Contents

Table of Contents

Typical Accessory Locations for NFPA/JIC Power Units	4-5
Drip Pans	6
Filler Breather / T.R.A.P.™ Breathers	7-9
Filters and Inlet Strainers	
Return Filters	10-15
In-Tank Filters	16-19
Pressure Filters	20-27
Inlet Strainers	28-29
Heat Exchangers	
Air-To-Oil	30-33
Water-To-Oil	34-36
Water Modulating Valves	37
“Y” Type Water Strainers	38
Tank Heaters	39
Pressure Switch	40
Temperature Switch	41
Level/Temperature Switches	42
Pressure Gauges	43
Needle Valve	44
Gauge Isolator	45
Air Bleed Valve	46
Rapid Response Relief Valves	47
Check Valves	48
Ball Valves - High and Low Pressure	49-50
Flow Meters	51
Sight Gauges	52-53
Reservoir Drain Valve	54
Magnets	55
Accumulator (Bladder)	56
Accumulator Dump Valve	57
Gear Pumps / Fixed Vane Pumps	
SAE-AA	58
SAE-A	59-61
Pump Motor Adaptors and Couplings	62-63
Electric Motors	64-67
Motor Starters	68-69

Power Unit Accessories

NFPA/JIC STYLE POWER UNITS

Typical Accessory Locations

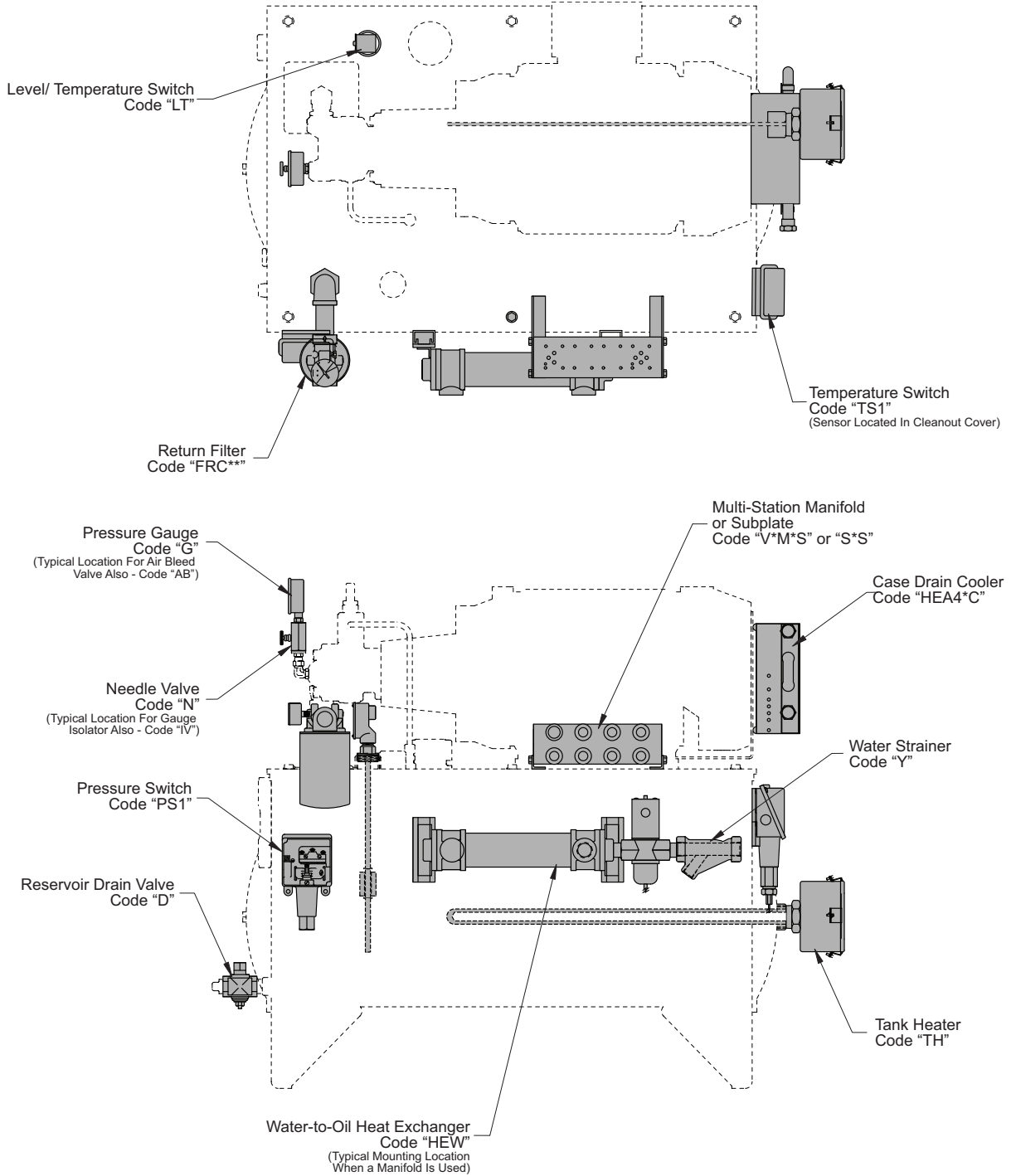

Power Unit Accessories
 NFPA/JIC STYLE POWER UNITS
 Typical Accessory Locations

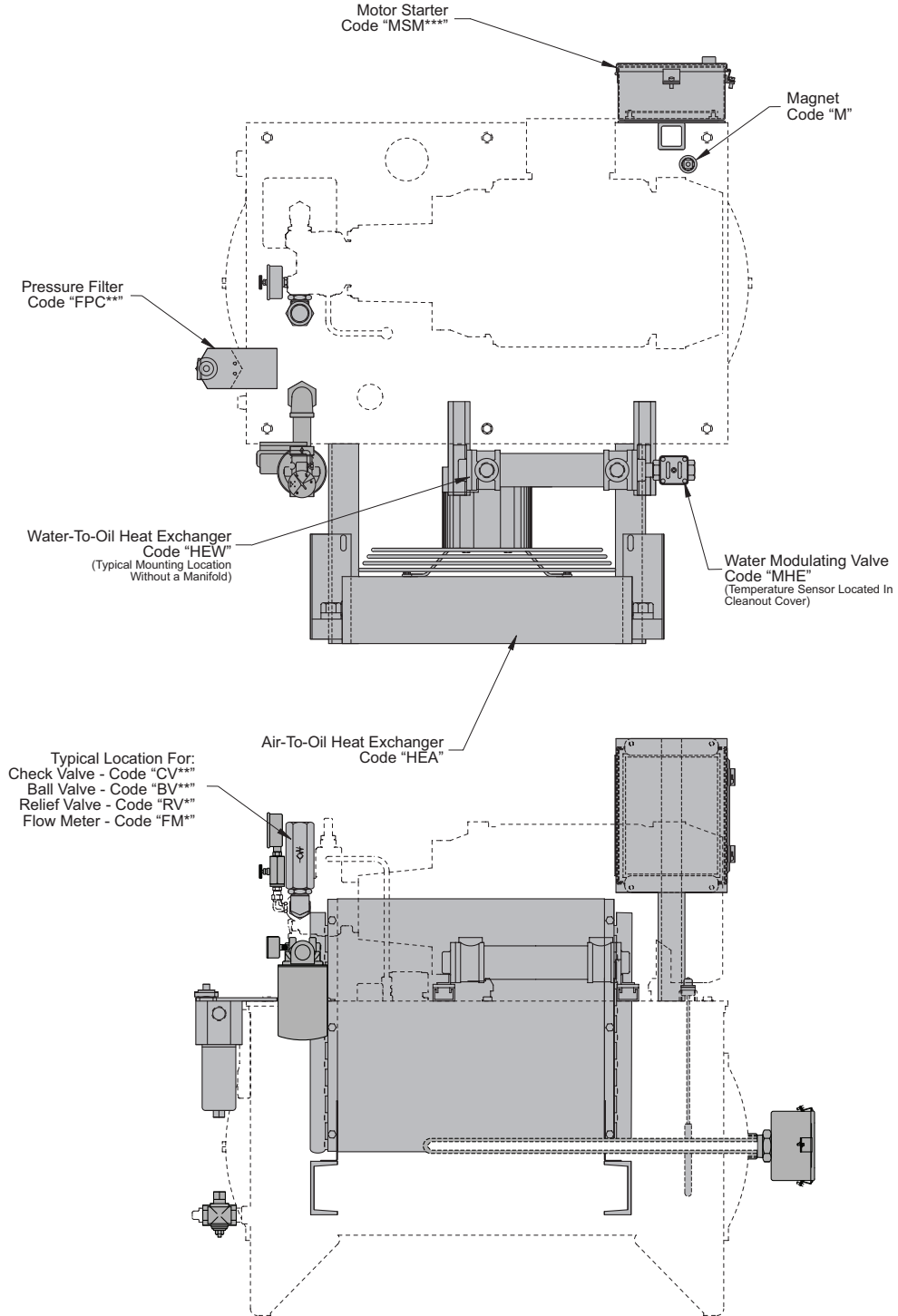

Power Unit Accessories

NFPA/JIC STYLE POWER UNITS

Drip Pans

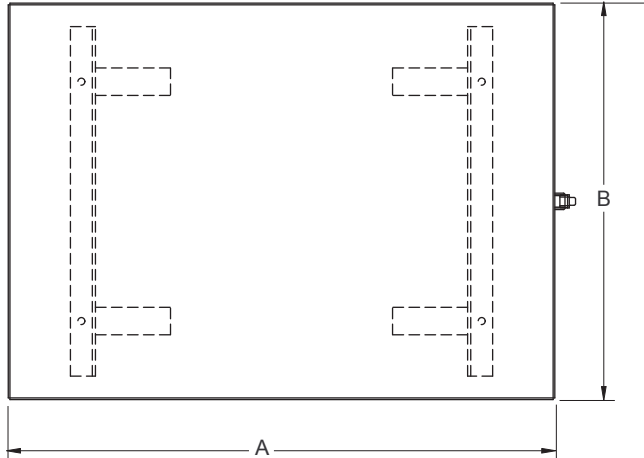

Dimensions shown in: Inches (± .125)
 (millimeters (± 1 mm))

Description: These drip pans are designed to mount directly under our standard NFPA/JIC style reservoirs.

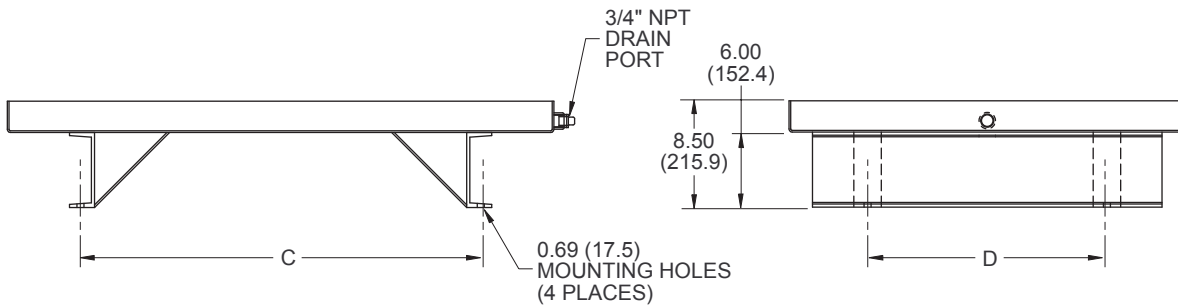

Dimensions

Model Code	Part Number	Dimension			
		A	B	C	D
R10DP	621259	28.00 (711.2)	24.50 (622.3)	21.00 (533.4)	13.00 (330.2)
R20DP	621260	36.00 (914.4)	24.50 (622.3)	29.00 (736.6)	13.00 (330.2)
R35DP	621261	42.00 (1066.8)	30.50 (744.7)	35.00 (889.0)	19.00 (330.2)
R50DP	621261	42.00 (1066.8)	30.50 (744.7)	35.00 (889.0)	19.00 (330.2)
R70DP	621262	54.00 (1371.6)	33.50 (850.9)	47.00 (1193.8)	22.00 (330.2)
R90DP	621263	66.00 (1676.4)	33.50 (850.9)	59.00 (1498.6)	22.00 (330.2)
R130DP	621264	66.00 (1676.4)	36.50 (927.1)	59.00 (1498.6)	25.00 (330.2)
R160DP	621264	66.00 (1676.4)	36.50 (927.1)	59.00 (1498.6)	25.00 (330.2)
R210DP	621265	78.00 (1981.2)	42.50 (1079.5)	71.00 (1803.4)	31.00 (330.2)

Model Code



Reservoir Capacity

Code	Description
R10	10 Gallons (37.8 liters)
R20	20 Gallons (75.7 liters)
R35	35 Gallons (132.5 liters)
R50	50 Gallons (189.2 liters)
R70	70 Gallons (254.9 liters)
R90	90 Gallons (340.6 liters)
R130	130 Gallons (492.0 liters)
R160	160 Gallons (605.6 liters)
R210	210 Gallons (794.8 liters)

Power Unit Accessories
 NFPA/JIC AND L-SHAPED POWER UNITS
Filler Breather

Dimensions shown in: Inches (± .125)
 (millimeters (± 1 mm))

Description: Filler Breathers are designed to be used as a filler port for hydraulic power units. This unit also lets the tank breathe while keeping out airborne particles.

- 10 Micron Foam Media
- 10CFM Air Flow Capacity
- 115 GPM Oil Transfer Rate

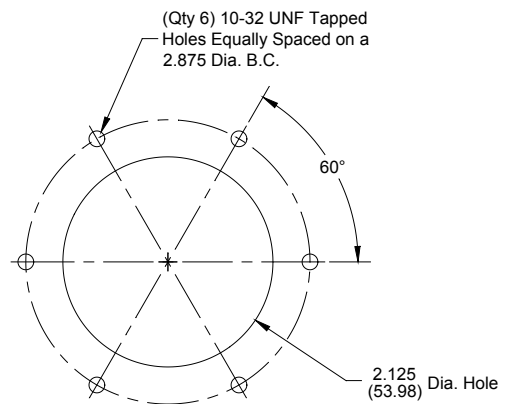
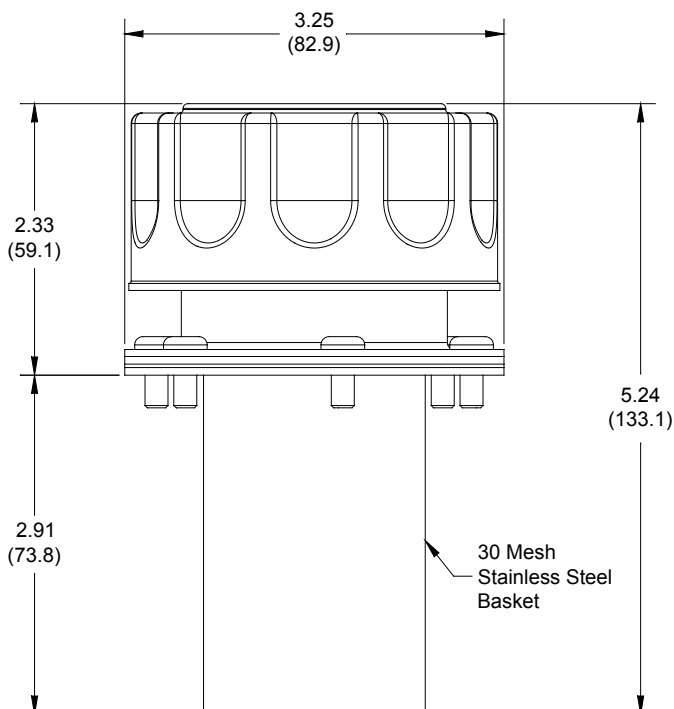
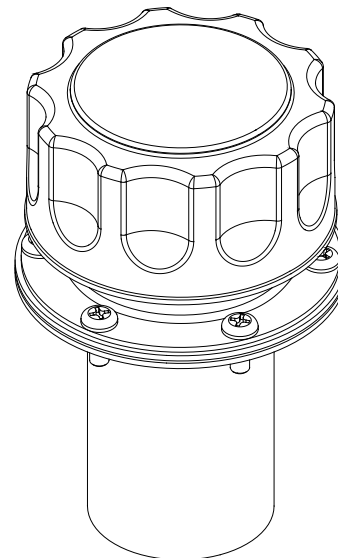
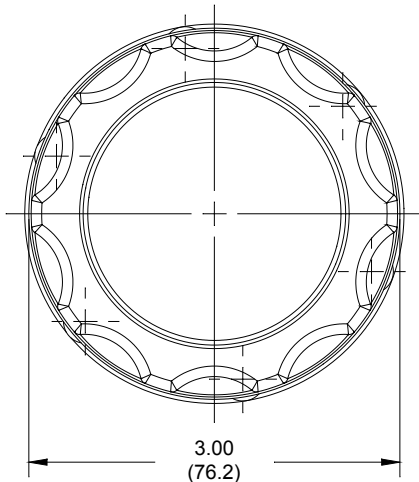

Model Code
 Filler Breather
FB
 Part # 136647

Power Unit Accessories
 NFPA/JIC AND L-SHAPED POWER UNITS



Dimensions shown in: Inches (± .125)
 (millimeters (± 1 mm))

Description: Keep moisture and dirt OUT of your hydraulic reservoir with Donaldson's innovative technology, the Thermally Reactive Advanced Protection (T.R.A.P.™) breather! It senses moisture and begins working faster and lasts longer than desiccant breathers. This is an entirely new technology that provides better protection for your oil or hydraulic fluid.

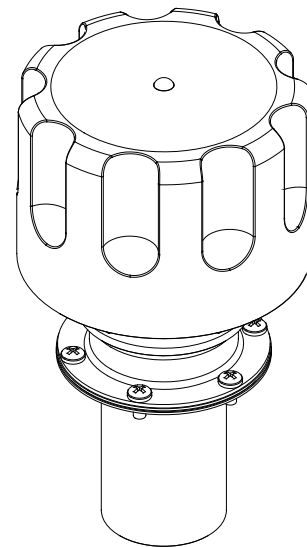
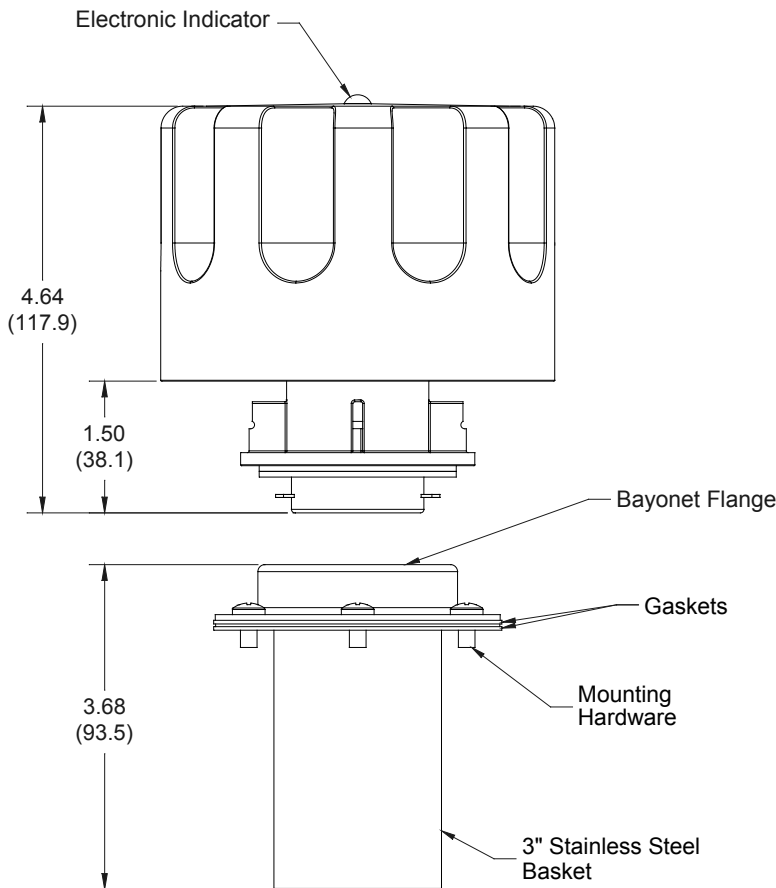
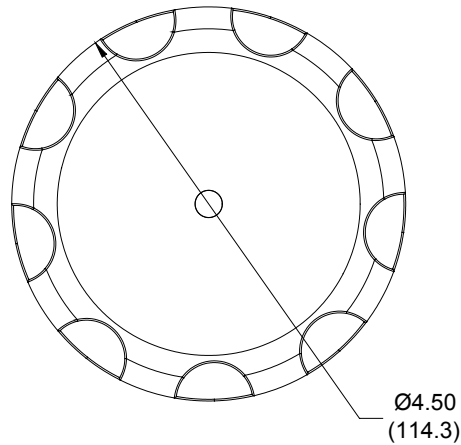

(Qty 6) 10-32 UNF Tapped Holes Equally Spaced on a 2.875 Dia. B.C.

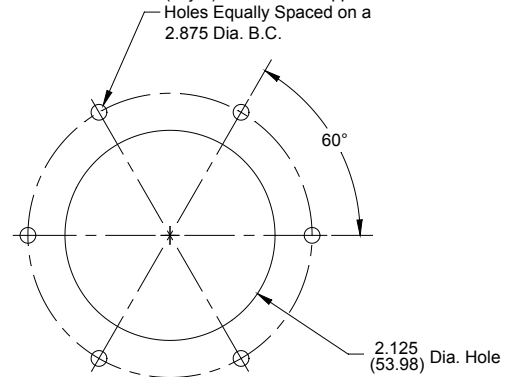

Model Code

Breather Bayonet

BY

Breather Part # 1001489*
 Basket Part # 1003956

*Breather 1001489 will not fit on the same basket that comes with the standard Filler Breather 136647.

Electronic Indicator Actuated by Pressure Differential, Flashes Red to Indicate Change Out is Needed. Indicator Setting, 1PSID.

Power Unit Accessories

NFPA/JIC STYLE AND L-SHAPED POWER UNITS

Return Filter - 10 gpm (37.8 lpm)



Dimensions shown in: Inches (± .125)
(millimeters (± 1 mm))

1/4"-20 UNC-2B x .50" Deep
2 Places

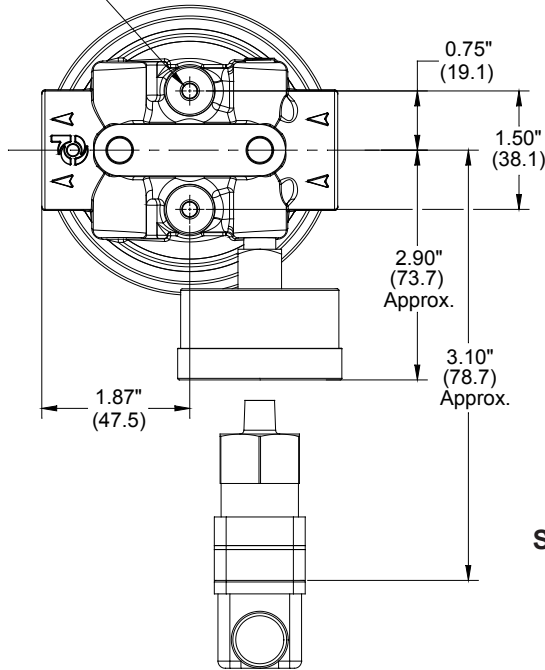

Description: Return filters can greatly increase the life of your hydraulic fluid and components. Filters should be sized to handle the maximum return flow of the system.

- 10 gpm (37.8 lpm)
- Maximum Pressure: 150 psi (11 bar)
- By-Pass Cracking Pressure: 25 psi (2 Bar)
- Visual Indicator Standard
- Electrical Indicator Optional

Wiring Code

Common = #1

N.O. = #3

N.C. = #2

Voltage

12 VDC, 7.0 Amp

24 VDC, 5.0 Amp

125/250 VAC, 5.0 Amp Inductive

Schematic Symbol

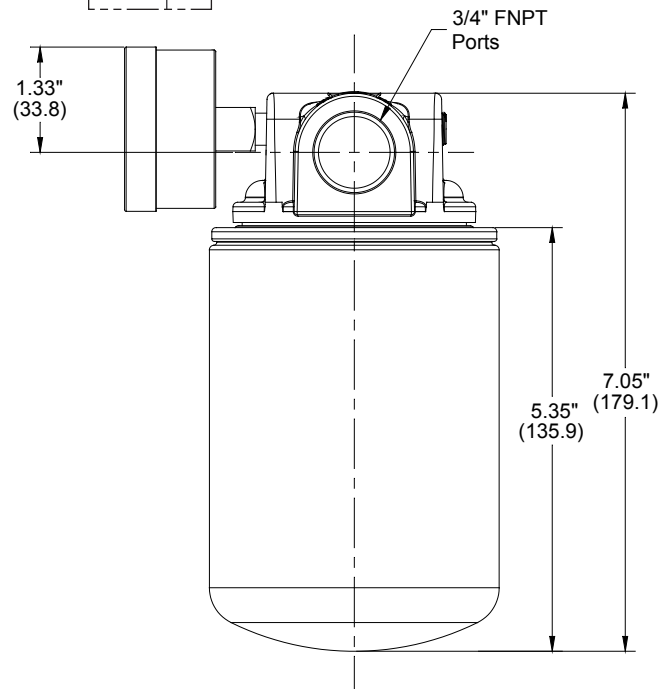
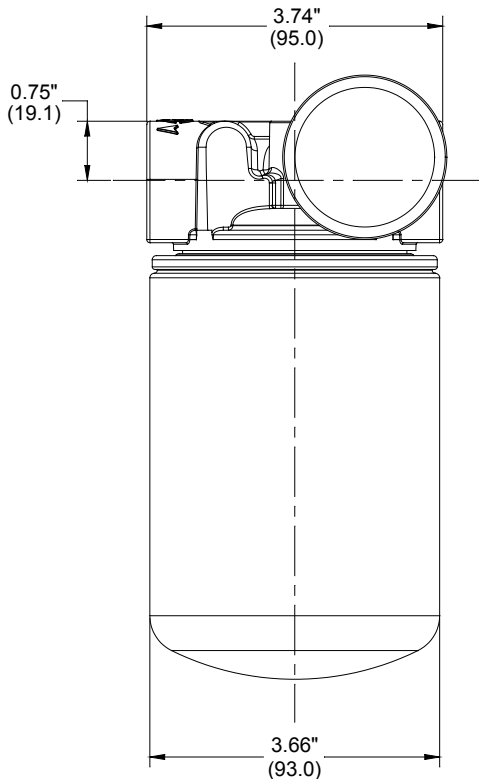
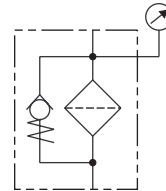

Power Unit Accessories
 NFPA/JIC AND L-SHAPED POWER UNITS
 Return Filter - 10 gpm (37.8 lpm)

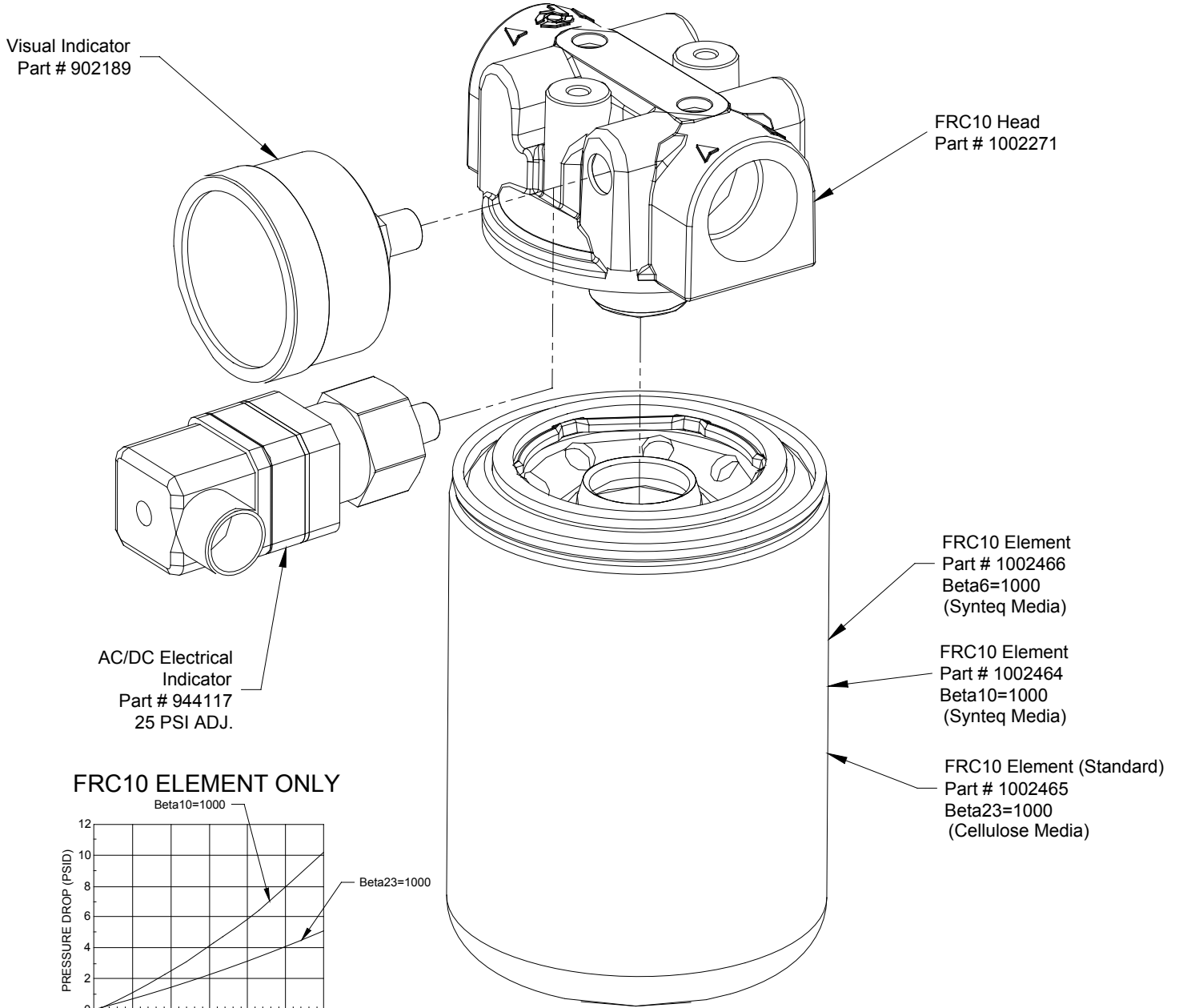

FRC10 ELEMENT ONLY

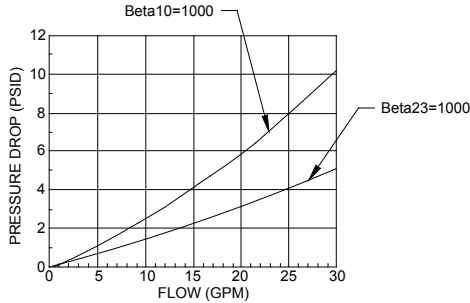

FRC10 HEAD ONLY

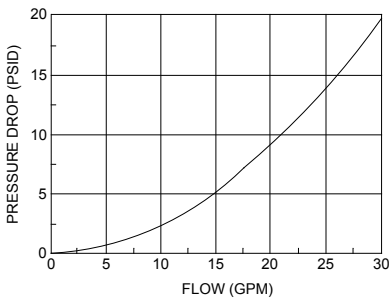

Model Code

Filter Return Flow
F R **10**

Indicator

Code	Description
C	Visual - #902189
E	Electrical - #944117

Power Unit Accessories

NFPA/JIC AND L-SHAPED POWER UNITS

Return Filter - 40 gpm (151.4 lpm)



Dimensions shown in: Inches ($\pm .125$)
(millimeters (± 1 mm))

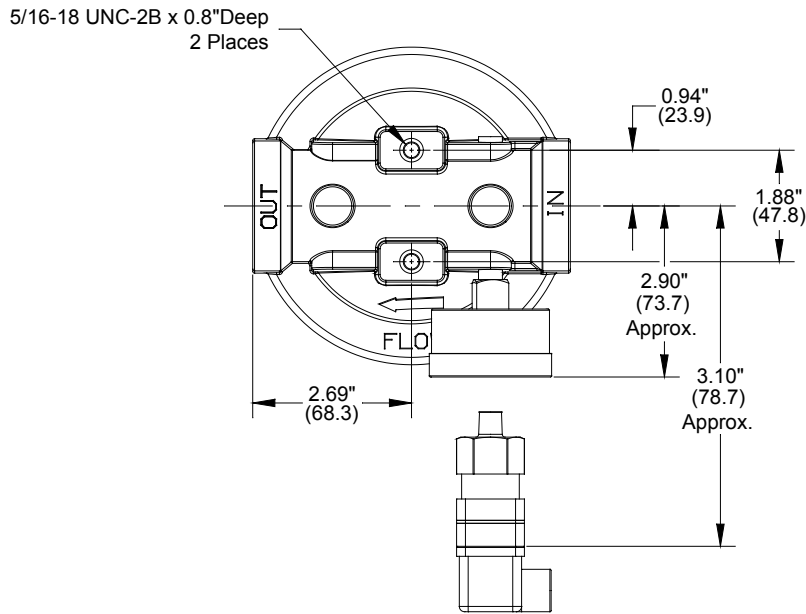

Description: Return filters can greatly increase the life of your hydraulic fluid and components. Filters should be sized to handle the maximum return flow of the system.

- 40 gpm (151.4 lpm)
- Maximum Pressure: 150 psi (11 bar)
- By-Pass Cracking Pressure: 25 psi (2 Bar)
- Visual Indicator Standard
- Electrical Indicator Optional

Wiring Code

Common = #1

N.O. = #3

N.C. = #2

Voltage

12 VDC, 7.0 Amp

24 VDC, 5.0 Amp

125/250 VAC, 5.0 Amp Inductive

Schematic Symbol

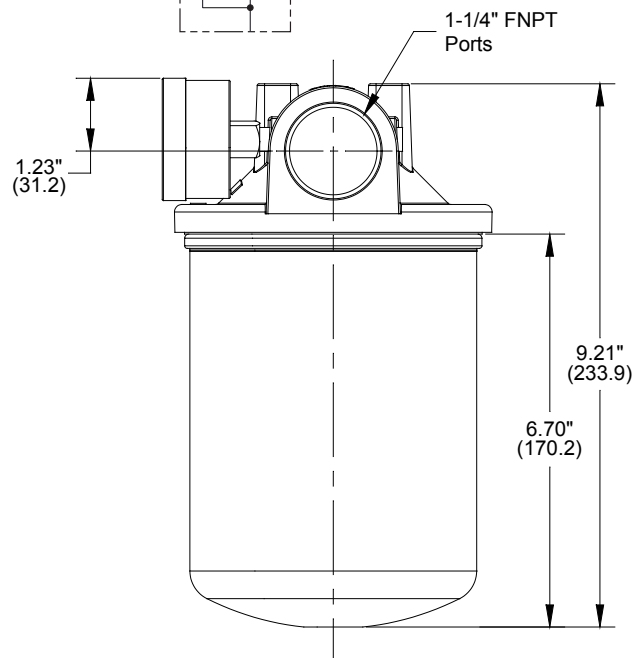
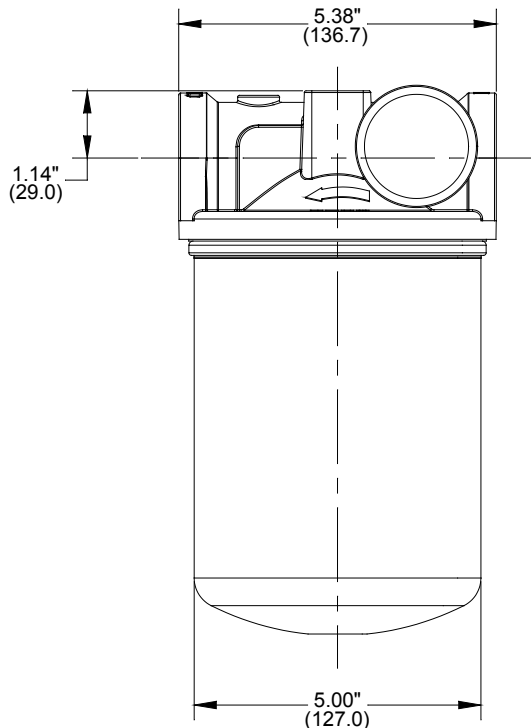
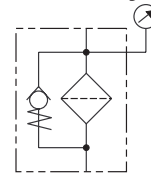

Power Unit Accessories
 NFPA/JIC AND L-SHAPED POWER UNITS
 Return Filter - 40 gpm (151.4 lpm)

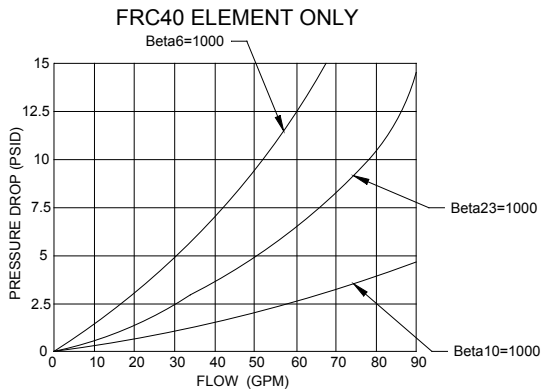
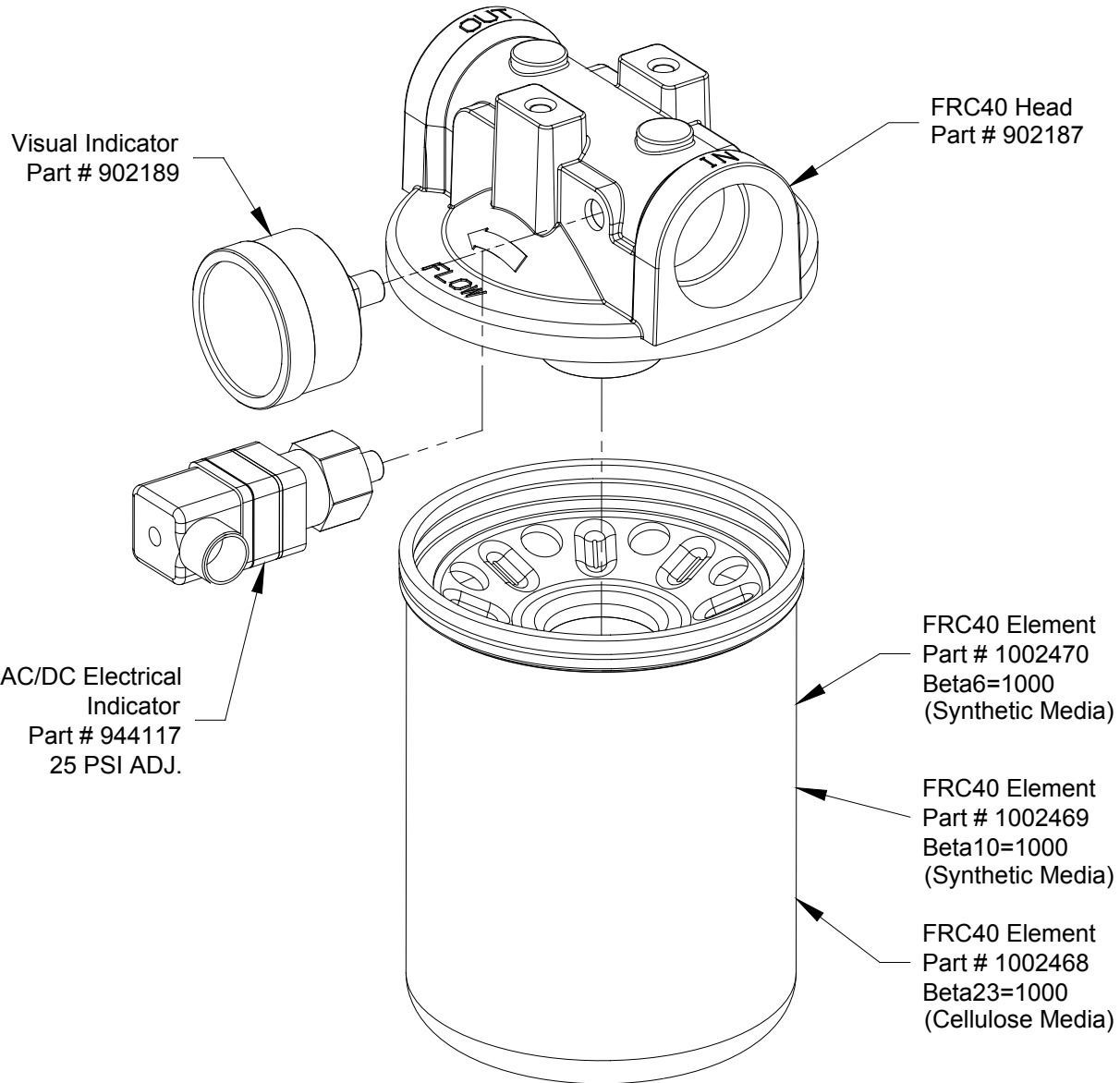

Model Code

Filter Return Flow

F R [] 40

Indicator

Code	Description
C	Visual - #902189
E	Electrical - #944117

Power Unit Accessories

NFPA/JIC AND L-SHAPED POWER UNITS

Return Filter - 80 gpm (302.8 lpm)

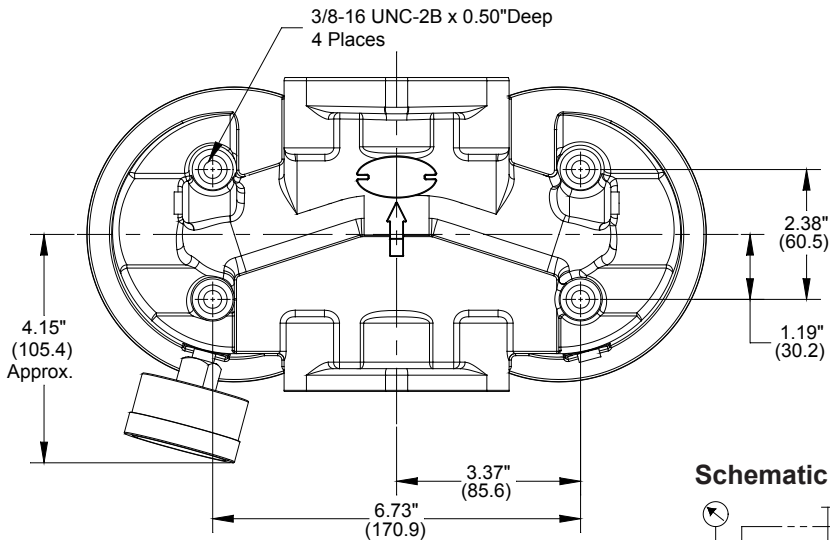

Dimensions shown in: Inches ($\pm .125$)
millimeters (± 1 mm)

Description: Return filters can greatly increase the life of your hydraulic fluid and components. Filters should be sized to handle the maximum return flow of the system.

- 80 gpm (302.8 lpm)
- Maximum Pressure: 150 psi (11 bar)
- By-Pass Cracking Pressure: 25 psi (2 Bar)
- Visual Indicator Standard
- Electrical Indicator Optional

Wiring Code

Common = #1

N.O. = #3

N.C. = #2

Voltage

12 VDC, 7.0 Amp

24 VDC, 5.0 Amp

125/250 VAC, 5.0 Amp Inductive

Schematic Symbol

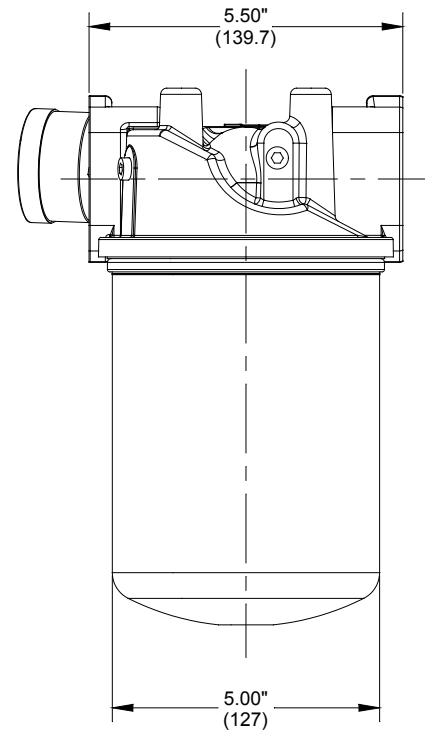
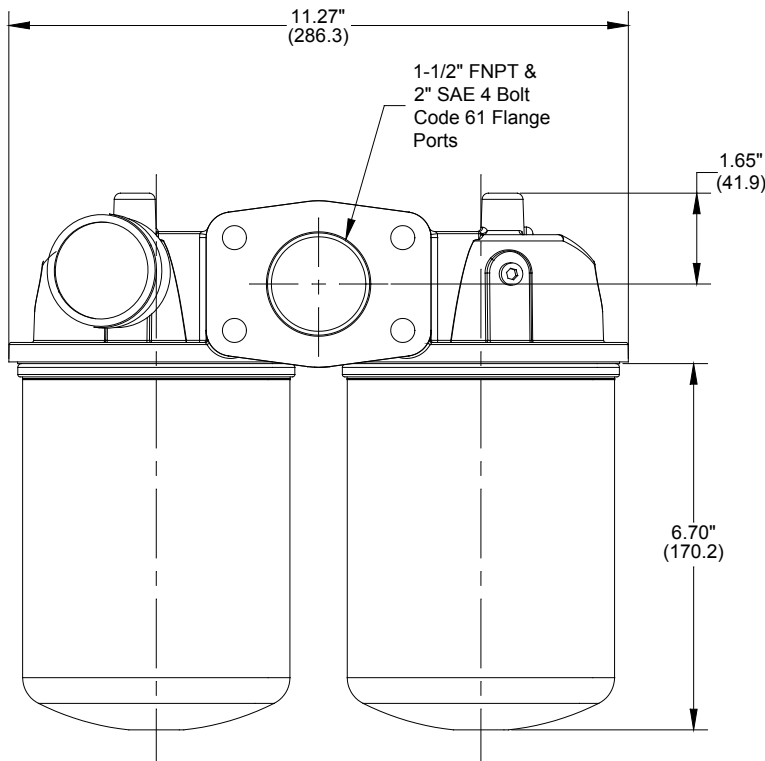
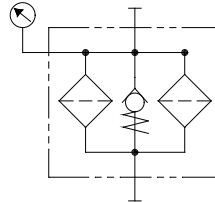

Power Unit Accessories
 NFPA/JIC AND L-SHAPED POWER UNITS
 Return Filter - 80 gpm (302.8 lpm)

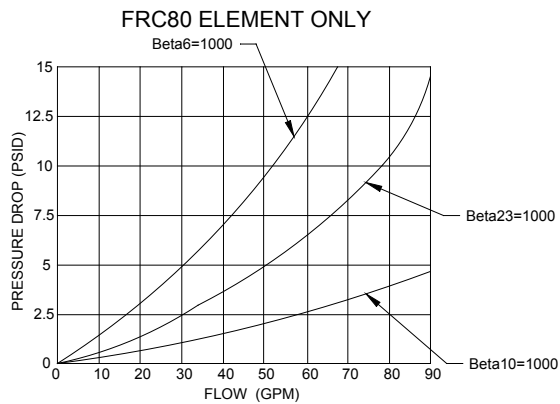
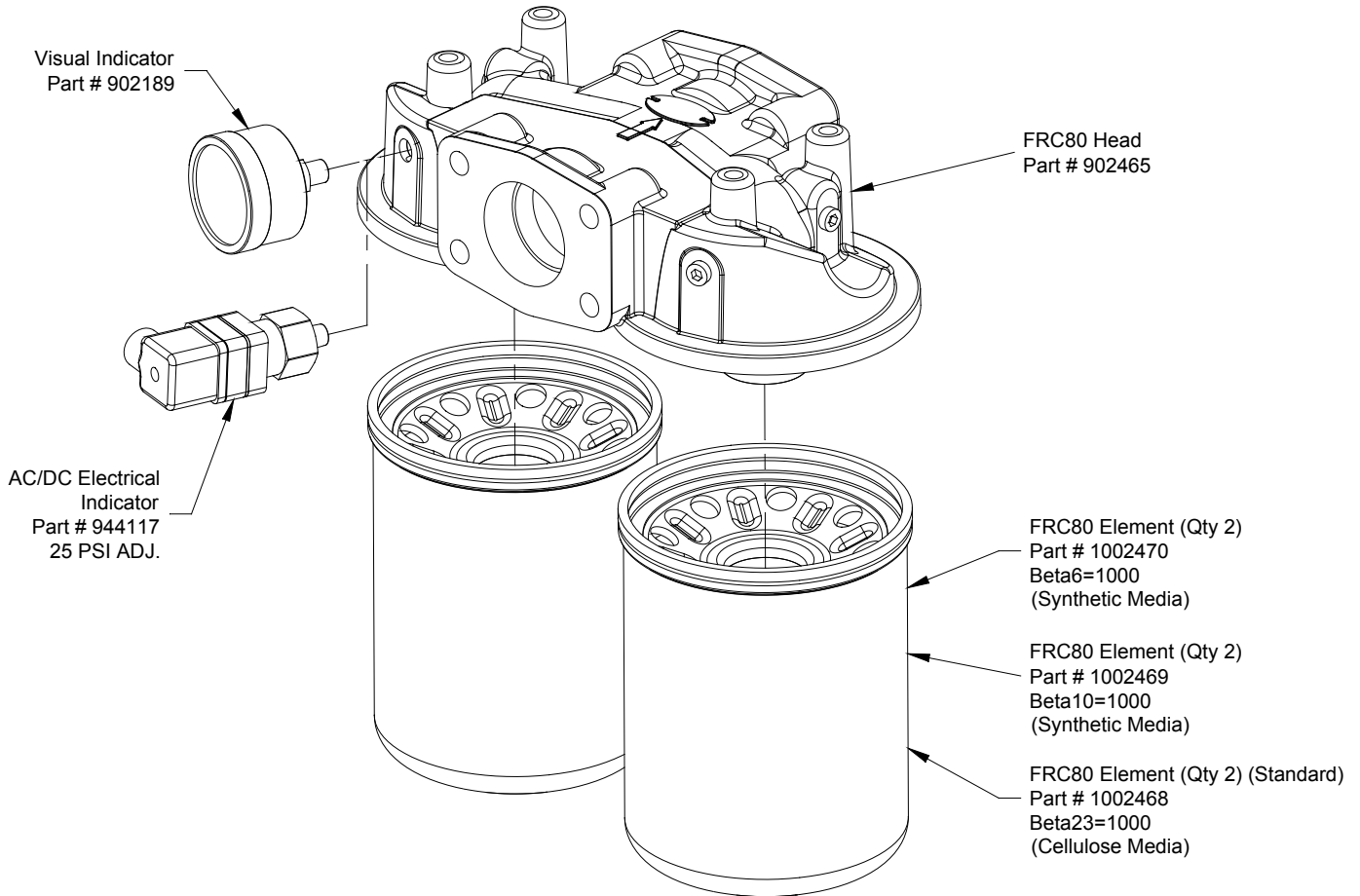

Model Code

Filter Return Flow

F R [] 80

Indicator

Code	Description
C	Visual - #902189
E	Electrical - #944117

Power Unit Accessories

LITTLE CHAMP®/LOW PROFILE POWER UNIT

In-Tank Return Filter - 14 gpm (52.9 lpm)



Dimensions shown in: Inches (± .125)
millimeters (± 1 mm)

Description: Return filters can greatly increase the life of your hydraulic fluid and components. Filters should be sized to handle the maximum return flow of the system.

- 14 gpm (52.9 lpm)
- Maximum Pressure: 145 psi (9.9 bar)
- By-Pass Cracking Pressure: 22 psi (1.5 Bar)
- Visual Indicator Standard
- Electrical Indicator Optional

Wiring Code

- Common = #1
- N.O. = #3
- N.C. = #2

Voltage

- 12 VDC, 7.0 Amp
- 24 VDC, 5.0 Amp
- 125/250 VAC, 5.0 Amp Inductive

Schematic Symbol

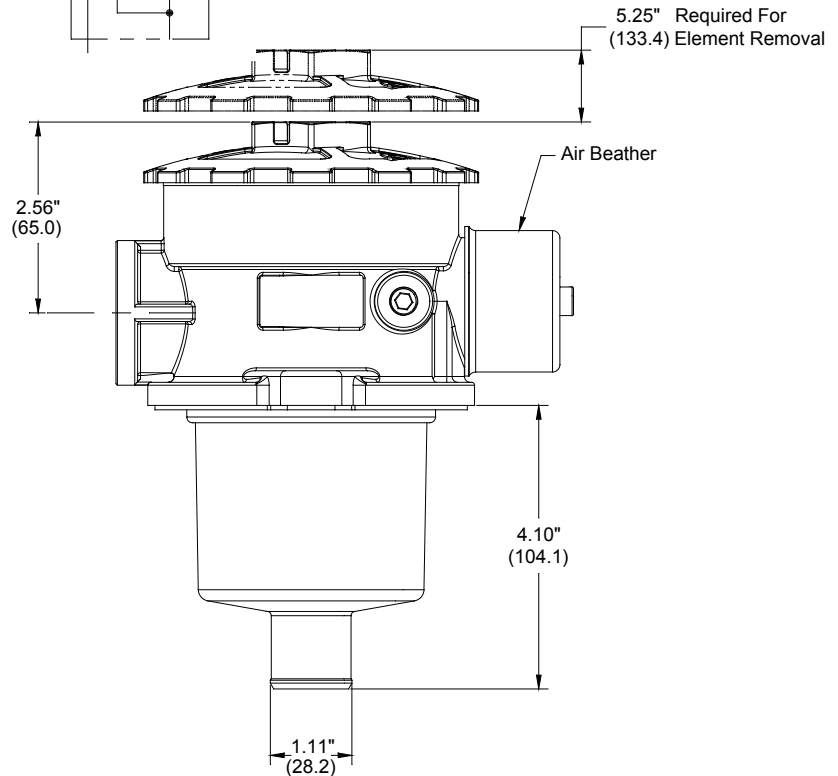
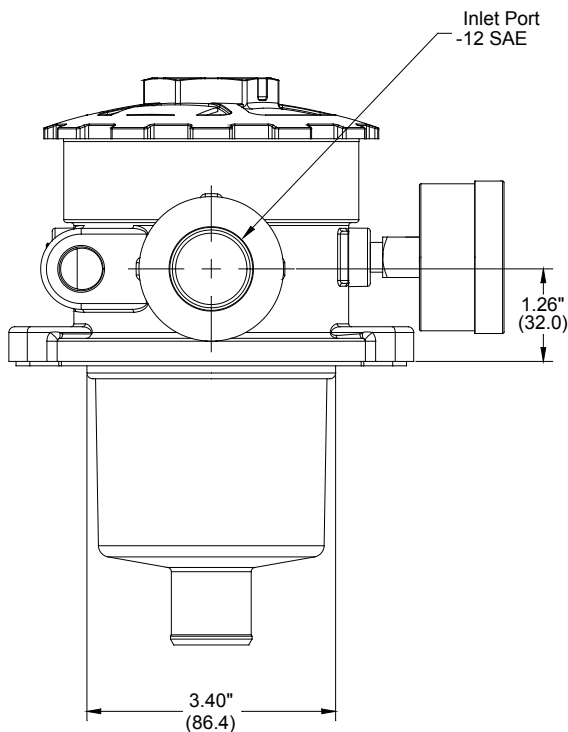
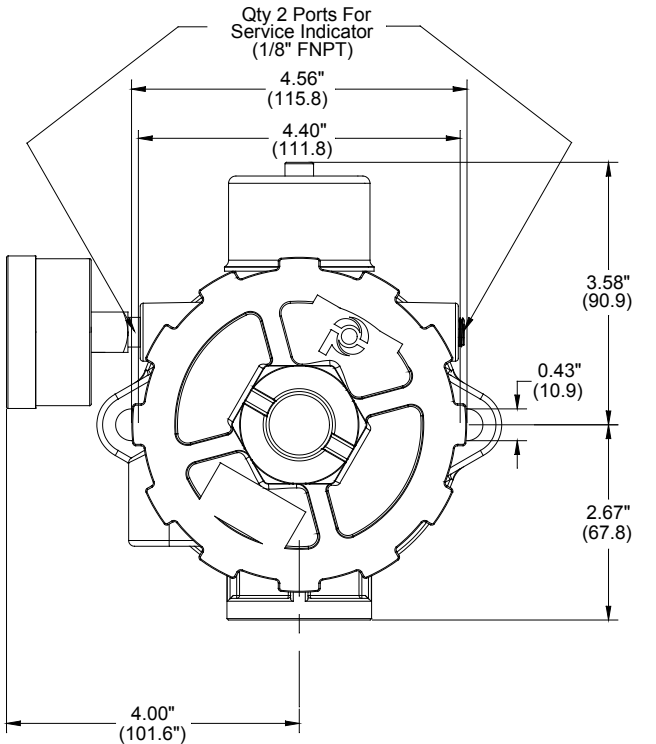
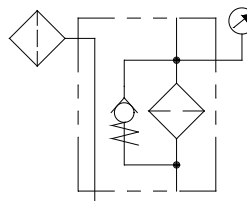

Power Unit Accessories
LITTLE CHAMP®/LOW PROFILE POWER UNIT
In-Tank Return Filter - 14 gpm (52.9 lpm)

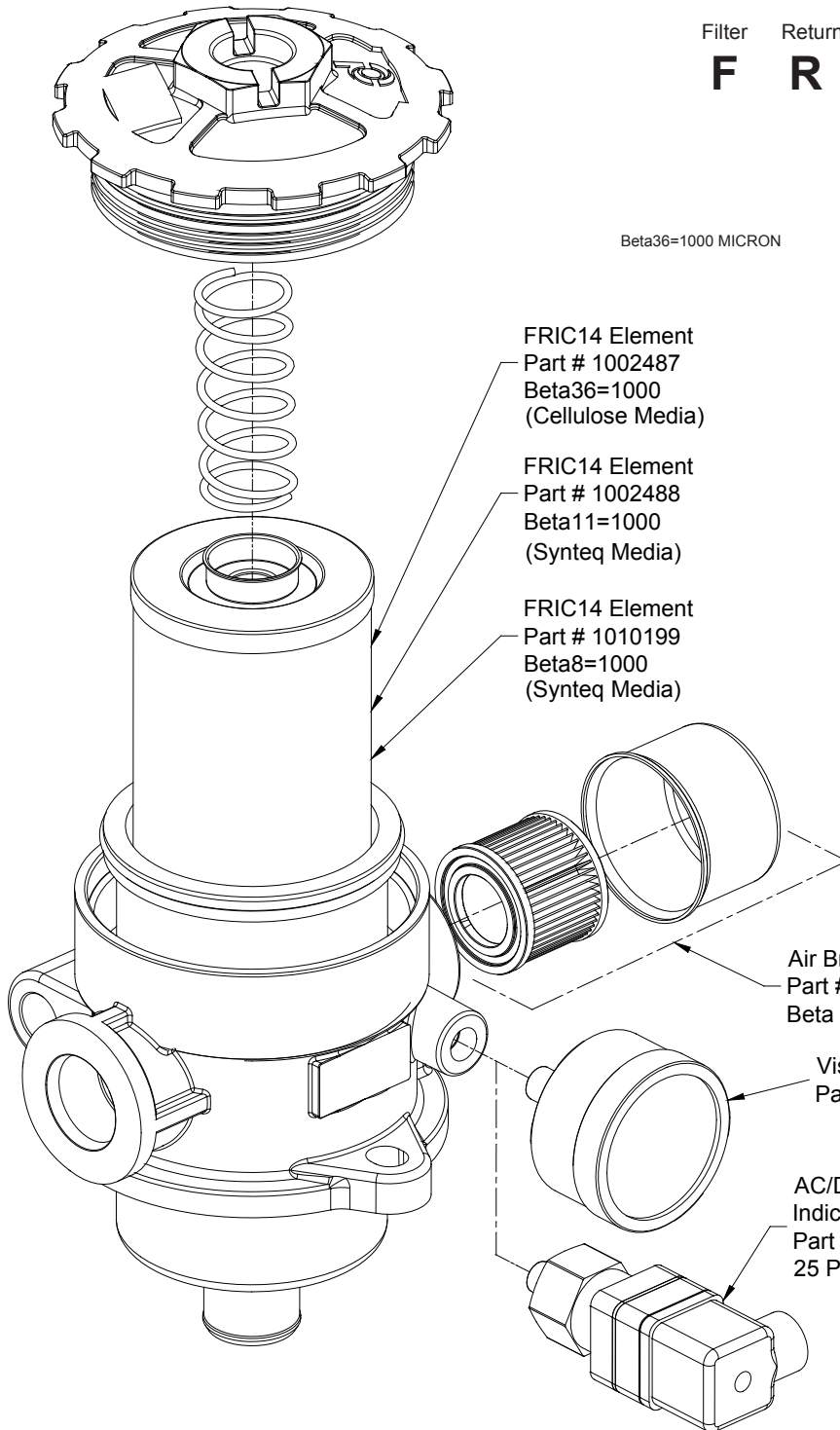

Beta36=1000 MICRON

FRIC14 Element
 Part # 1002487
 Beta36=1000
 (Cellulose Media)

FRIC14 Element
 Part # 1002488
 Beta11=1000
 (Synteq Media)

FRIC14 Element
 Part # 1010199
 Beta8=1000
 (Synteq Media)

Air Breather
 Part # 1002438
 Beta 10um

Visual Indicator
 Part # 902189

AC/DC Electrical
 Indicator
 Part # 944117
 25 PSI ADJ.

Model Code

Filter Return In-Tank Flow
F R I 14



Indicator

Code	Description
C	Visual - #902189
E	Electrical - #944117

FR1*14 With Beta36=1000 Element Part #1002555

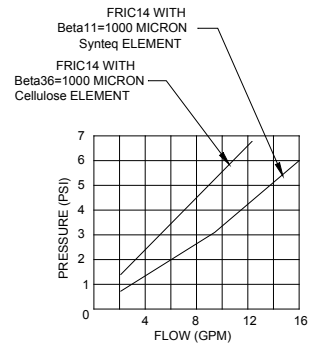

150 SUS OIL WITH SPECIFIC GRAVITY OF ≤0.9

Power Unit Accessories

LITTLE CHAMP®/LOW PROFILE POWER UNIT

In-Tank Return Filter - 25 gpm (94.6 lpm)

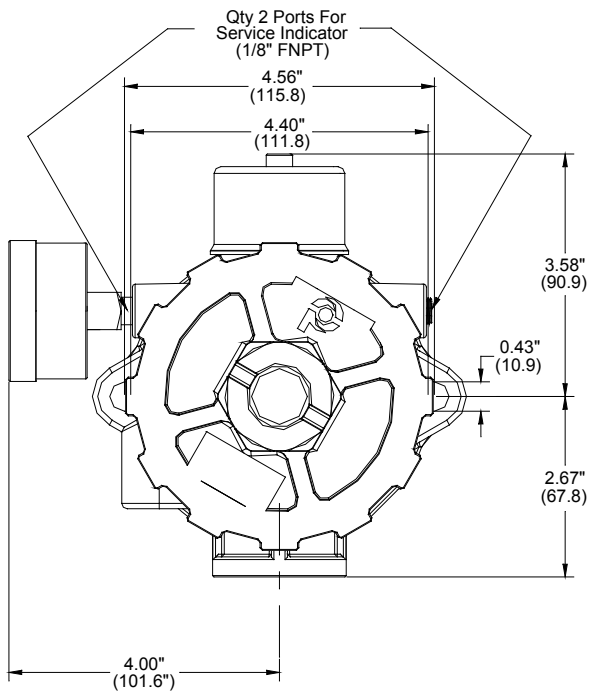

Dimensions shown in: Inches ($\pm .125$)
 (millimeters (± 1 mm))

Description: Return filters can greatly increase the life of your hydraulic fluid and components. Filters should be sized to handle the maximum return flow of the system.

- 25 gpm (94.6 lpm)
- Maximum Pressure: 145 psi (9.9 bar)
- By-Pass Cracking Pressure: 22 psi (1.5 Bar)
- Visual Indicator Standard
- Electrical Indicator Optional

Schematic Symbol

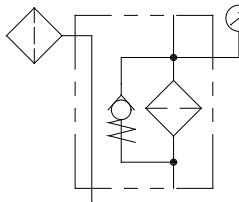

Wiring Code

Common = #1

N.O. = #3

N.C. = #2

Voltage

12 VDC, 7.0 Amp

24 VDC, 5.0 Amp

125/250 VAC, 5.0 Amp Inductive

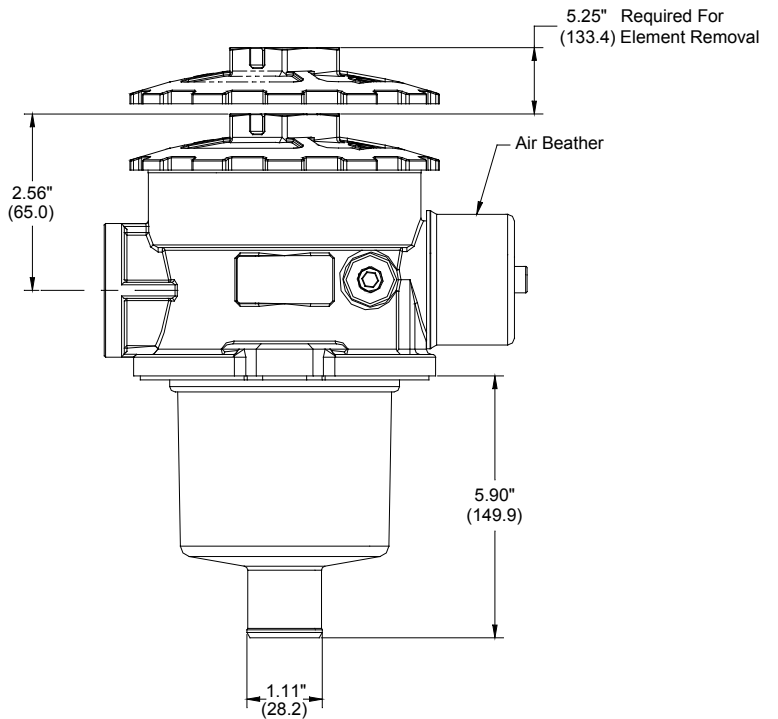
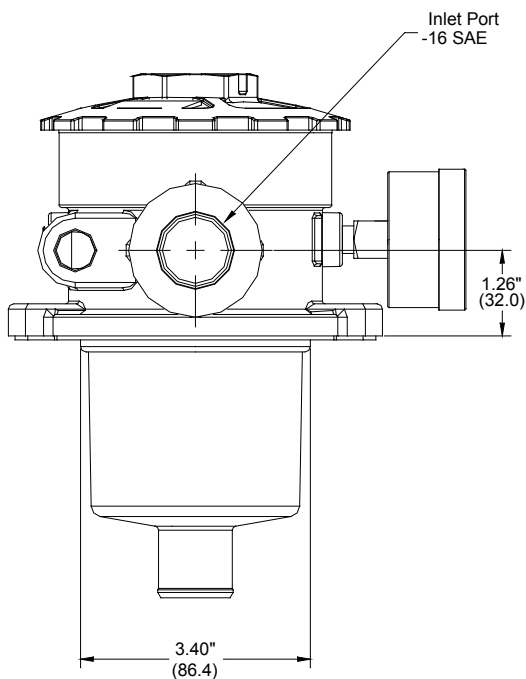

Power Unit Accessories

LITTLE CHAMP®/LOW PROFILE POWER UNIT

In-Tank Return Filter - 25 gpm (94.6 lpm)

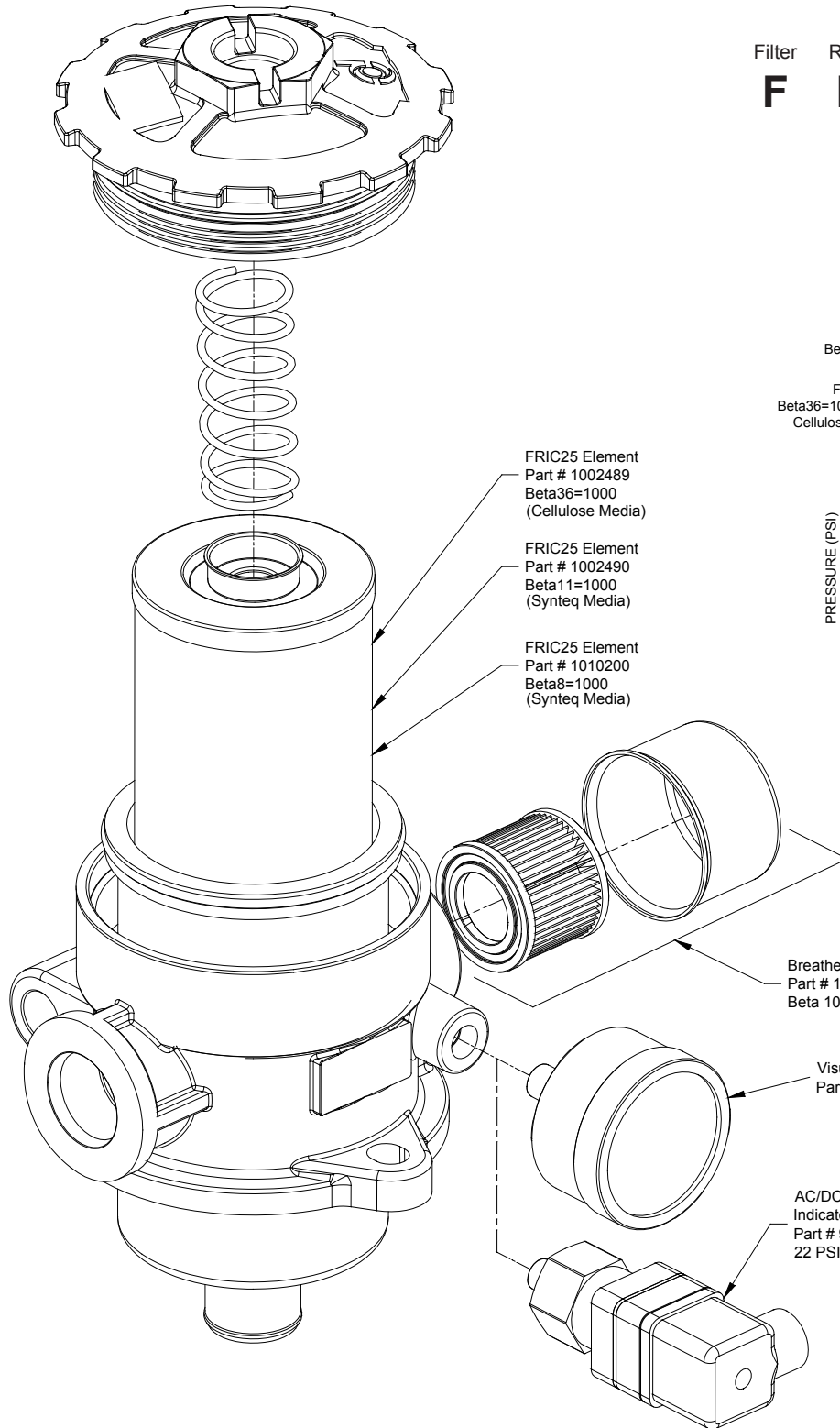

FRIC25 Element
 Part # 1002489
 Beta36=1000
 (Cellulose Media)

FRIC25 Element
 Part # 1002490
 Beta11=1000
 (Synteq Media)

FRIC25 Element
 Part # 1010200
 Beta8=1000
 (Synteq Media)

Breather Kit
 Part # 1002438
 Beta 10um

Visual Indicator
 Part # 902189

AC/DC Electrical
 Indicator
 Part # 944117
 22 PSI ADJ.

Model Code

Filter Return In-Tank Flow
F R I [] 25

Indicator

Code	Description
C	Visual - #902189
E	Electrical - #944117

FR1*25 With Beta36=1000 Element Part #1002556

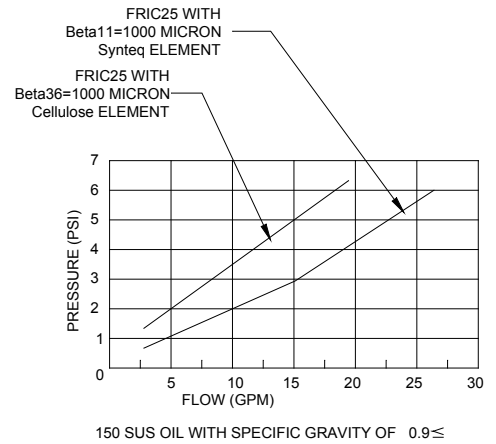

Power Unit Accessories

NFPA/JIC STYLE AND L-SHAPED POWER UNITS

Pressure Filter - 10 gpm (37.8 lpm)

Dimensions shown in: Inches ($\pm .125$)
 millimeters (± 1 mm)

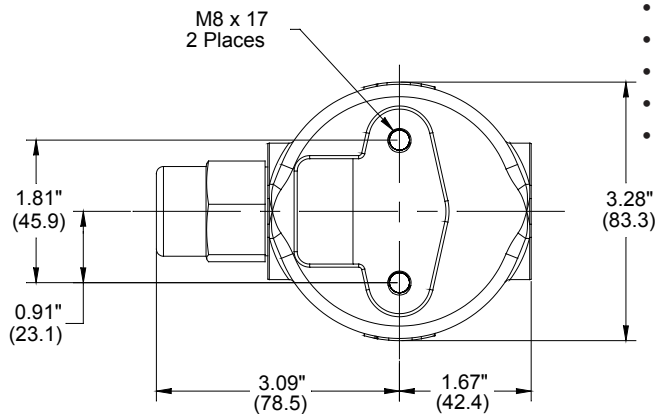

Description: Pressure filters ensure the most positive type of filtration and provide clean fluid for sensitive pressure line components.

- 10 gpm (37.8 lpm)
- Maximum Pressure: 6090 psi (419 bar)
- By-Pass Cracking Pressure: 87 psi (6 Bar)
- Buna-N Seals Standard
- SAE O-Ring Ported
- Visual Indicator Standard
- Electrical Indicator Optional

Schematic Symbol

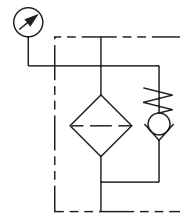

Wiring Code

Common = #1

N.O. = #3

N.C. = #2

Rating

6.0 Amps @ 120 VAC

3.0 Amps @ 240 VAC

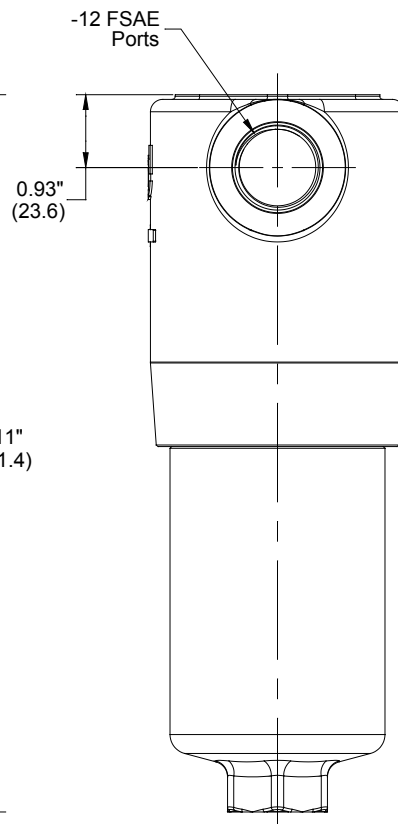
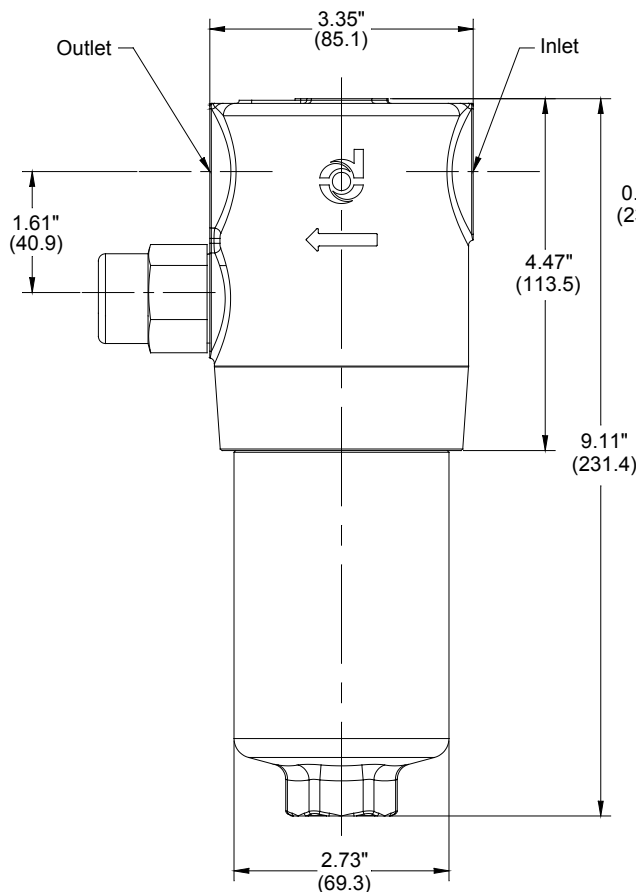

Power Unit Accessories
 NFPA/JIC STYLE AND L-SHAPED POWER UNITS
 Pressure Filter - 10 gpm (37.8 lpm)

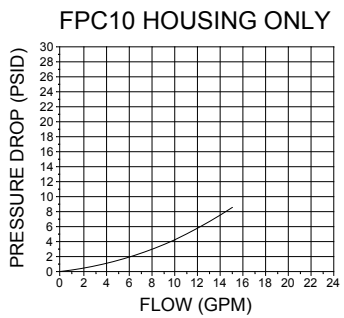
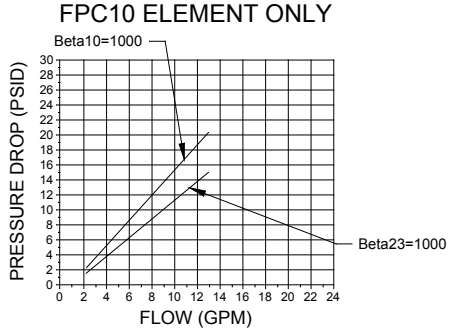
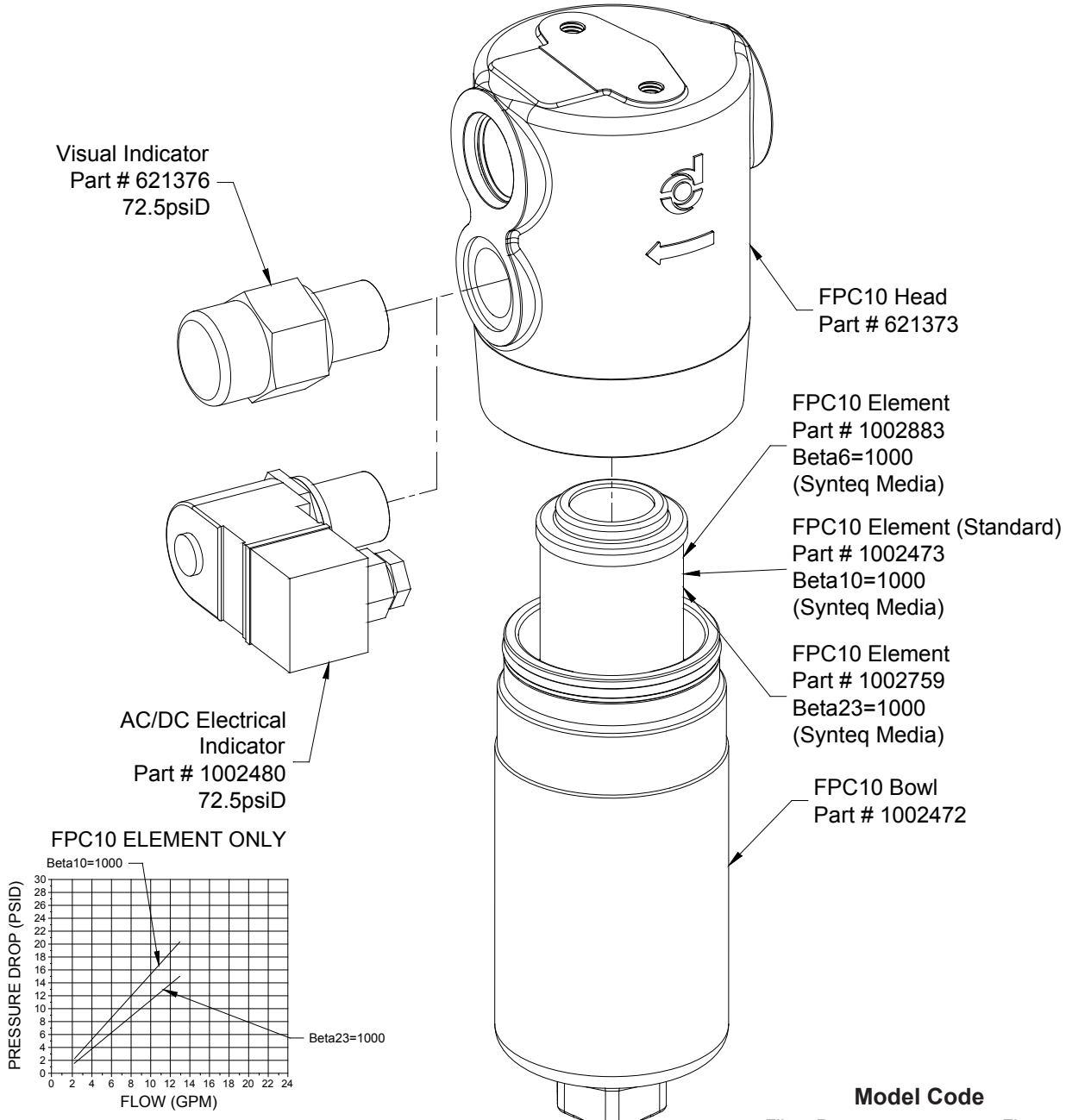

Model Code

Filter Pressure Flow

F P [] 10

Indicator

Code	Description
C	Visual - #621376
E	Electrical - #1002480

Power Unit Accessories

NFPA/JIC STYLE AND L-SHAPED POWER UNITS

Pressure Filter - 20 gpm (75.7 lpm)

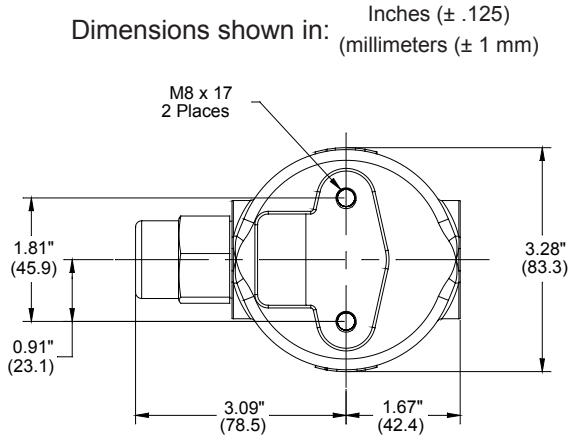

Description: Pressure filters ensure the most positive type of filtration and provide clean fluid for sensitive pressure line components.

- 20 gpm (75.7 lpm)
- Maximum Pressure: 6090 psi (419 bar)
- By-Pass Cracking Pressure: 87 psi (6 Bar)
- Buna-N Seals Standard
- SAE O-Ring Ported
- Visual Indicator Standard
- Electrical Indicator Optional

Wiring Code

- Common = #1
- N.O. = #3
- N.C. = #2

Rating

- 6.0 Amps @ 120 VAC
- 3.0 Amps @ 240 VAC

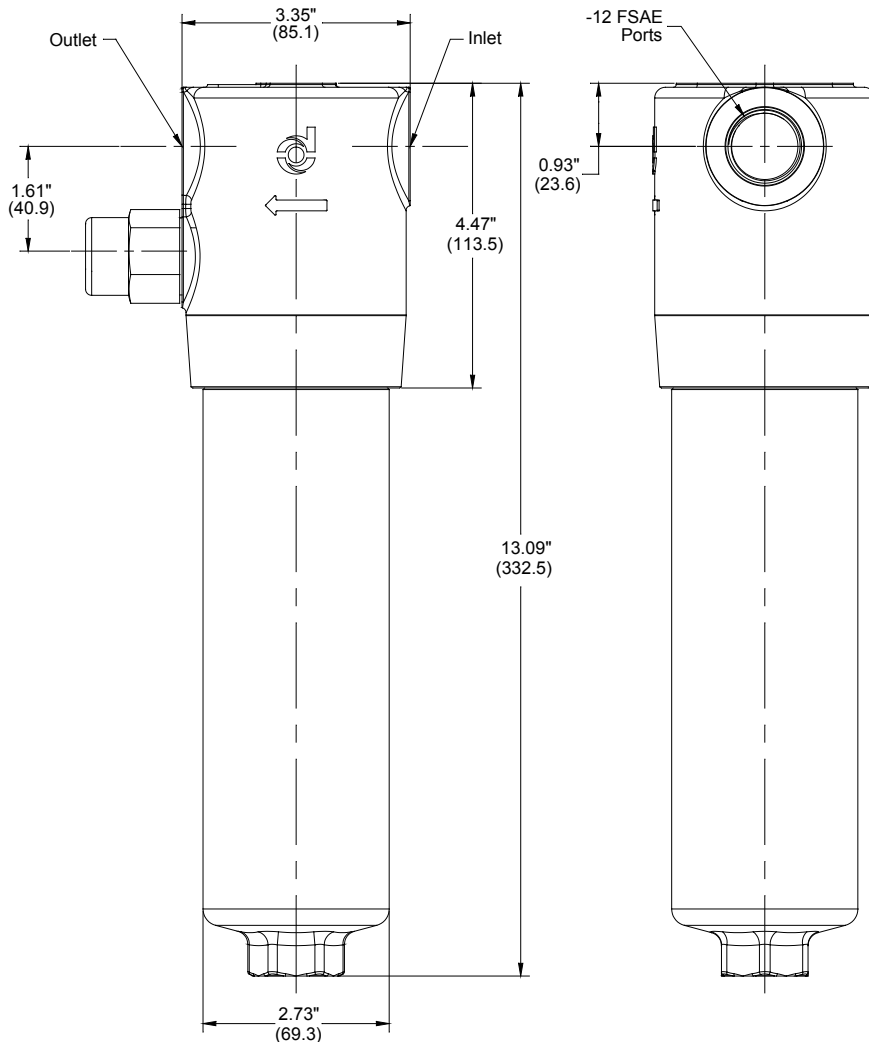

Schematic Symbol

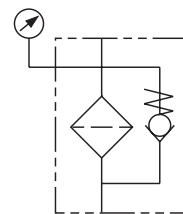

Power Unit Accessories
 NFPA/JIC STYLE AND L-SHAPED POWER UNITS
 Pressure Filter - 20 gpm (75.7 lpm)

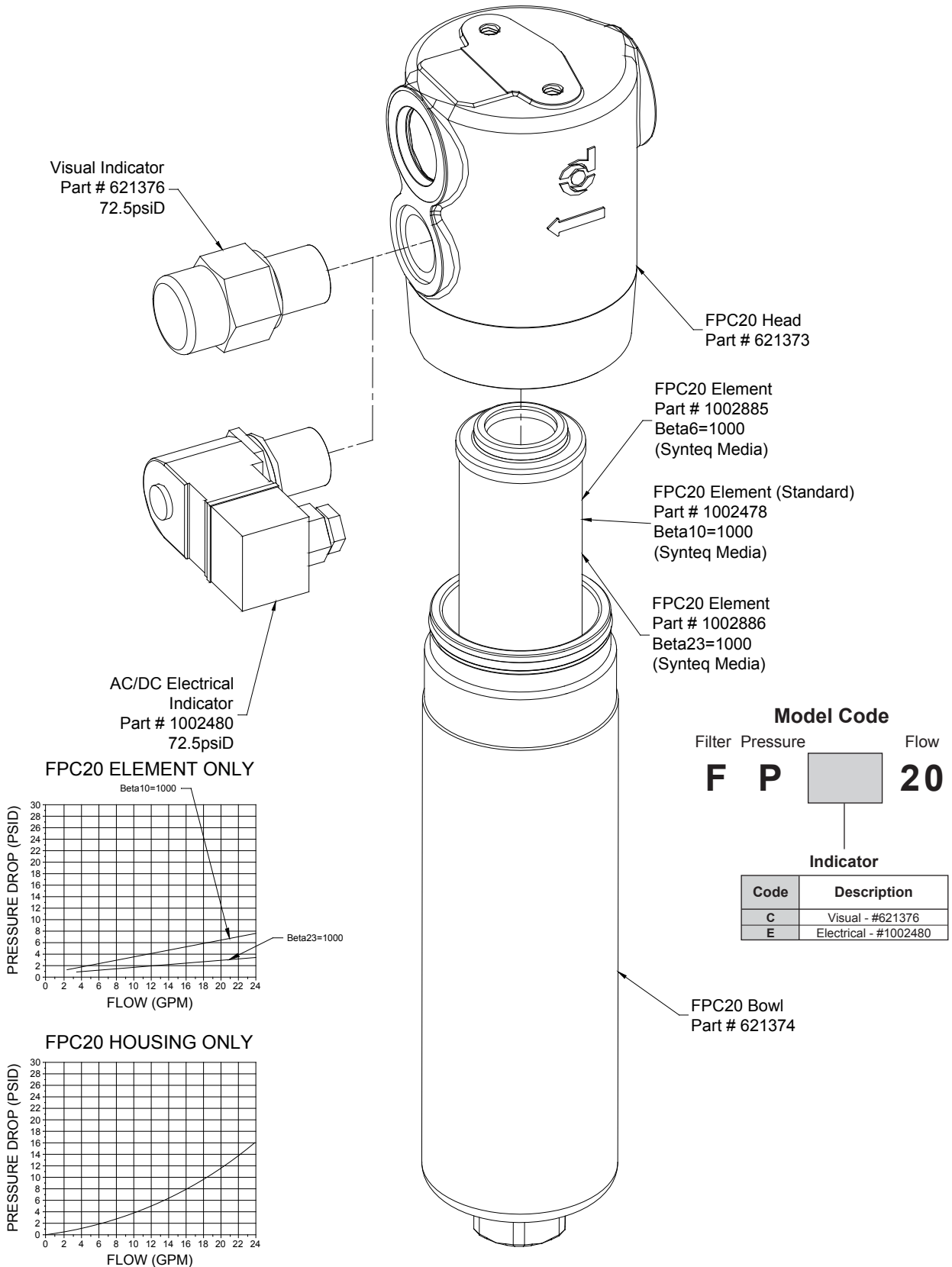

Power Unit Accessories

NFPA/JIC STYLE AND L-SHAPED POWER UNITS

Pressure Filter - 50 gpm (187.3 lpm)

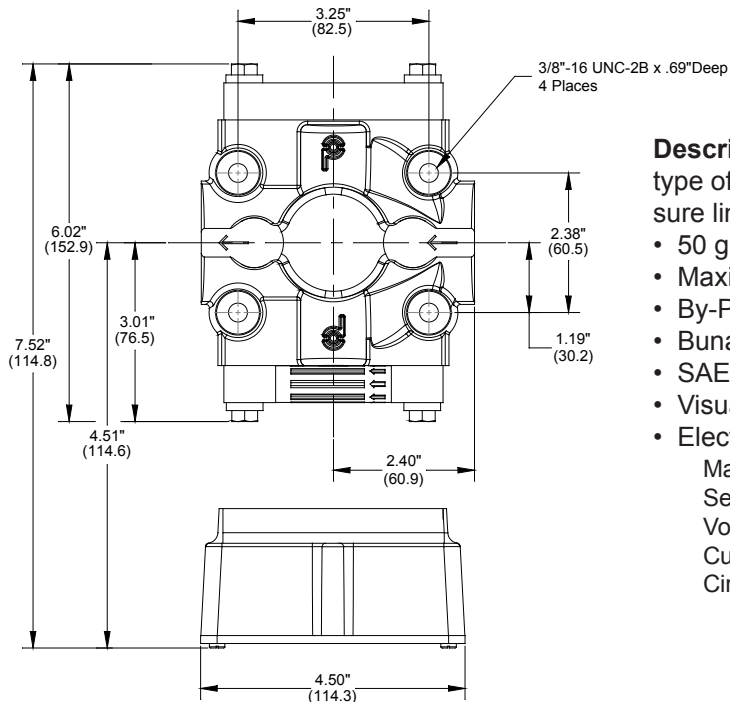

Dimensions shown in: Inches (± .125)
(millimeters (± 1 mm))

Description: Pressure filters ensure the most positive type of filtration and provide clean fluid for sensitive pressure line components.

- 50 gpm (187.3 lpm)
- Maximum Pressure: 3000 psi (207 bar)
- By-Pass Cracking Pressure: 50 psi (3 Bar)
- Buna-N Seals Standard
- SAE O-Ring Ported
- Visual Indicator Standard
- Electrical Indicator Optional:
 - Max Temp: 250F/121C
 - Set: 40 psi / 276kPa
 - Voltage: 120 VAC / 28 VDC
 - Current: 250 mA
 - Circuit: Normally Open (RED)
 - Normally Closed (BLUE)
 - Common (WHITE)

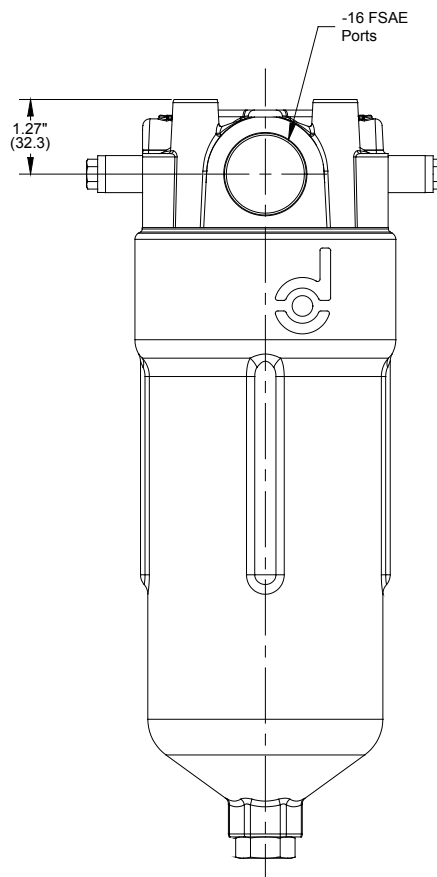
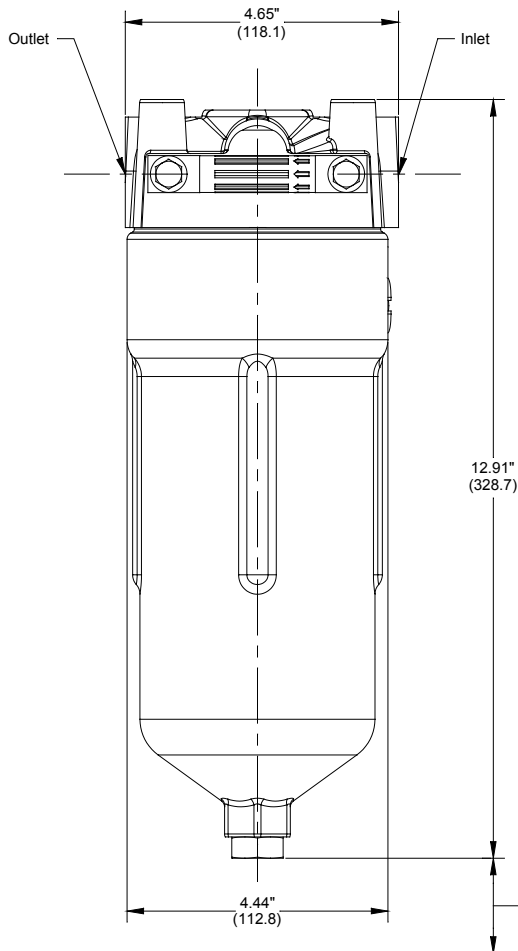

Schematic Symbol

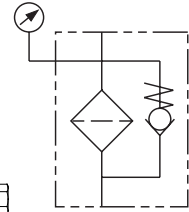

Power Unit Accessories
 NFPA/JIC STYLE AND L-SHAPED POWER UNITS
 Pressure Filter - 50 gpm (187.3 lpm)

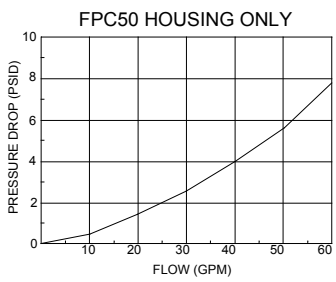
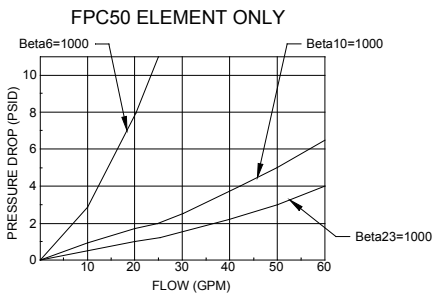
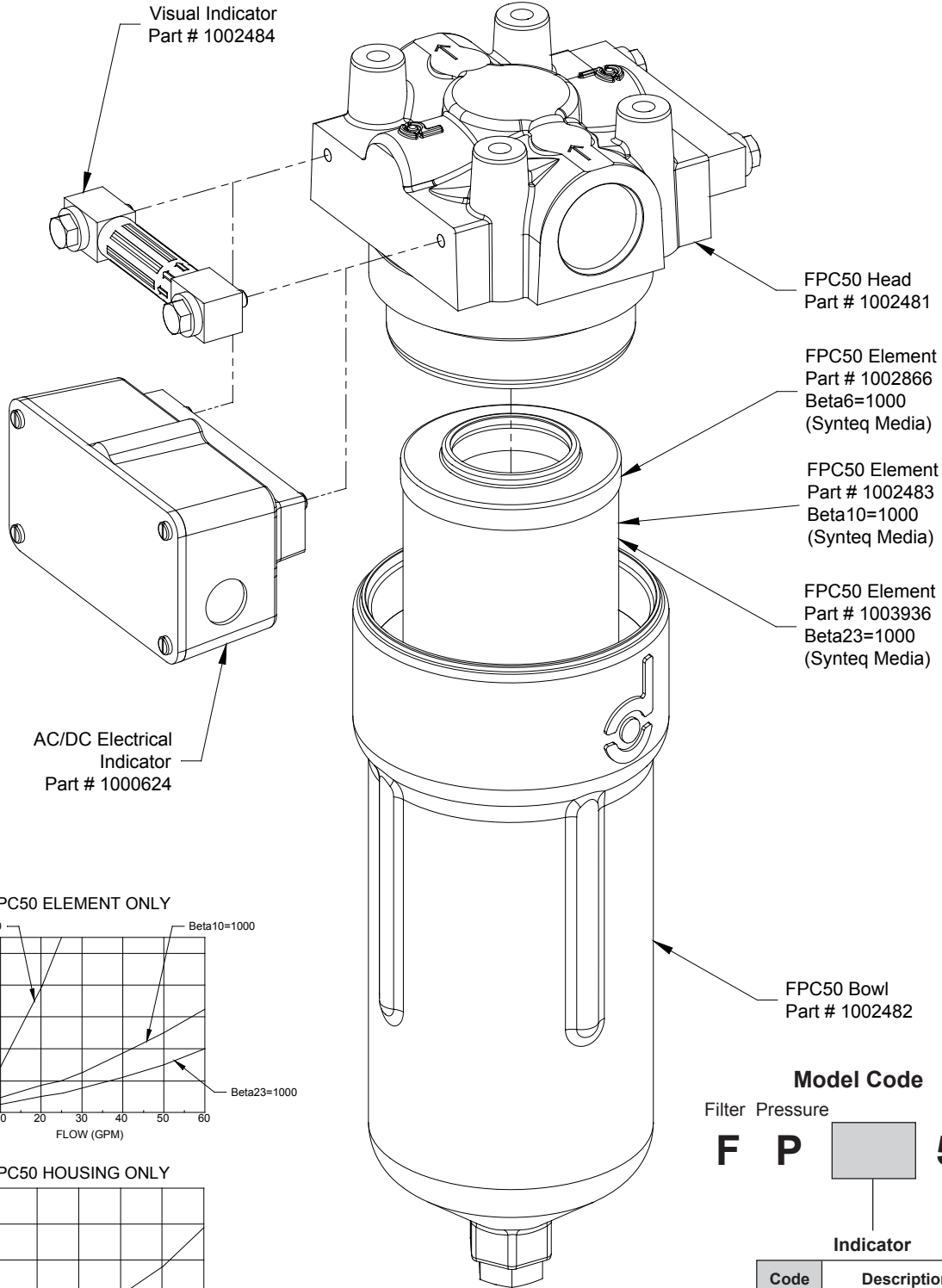

Model Code

Filter Pressure Flow

F P **50**

Indicator

Code	Description
C	Visual - #1002484
E	Electrical - #1000624

Power Unit Accessories

NFPA/JIC STYLE AND L-SHAPED POWER UNITS

Pressure Filter - 70 gpm (264.9 lpm)



Dimensions shown in: Inches ($\pm .125$)
 (millimeters (± 1 mm))

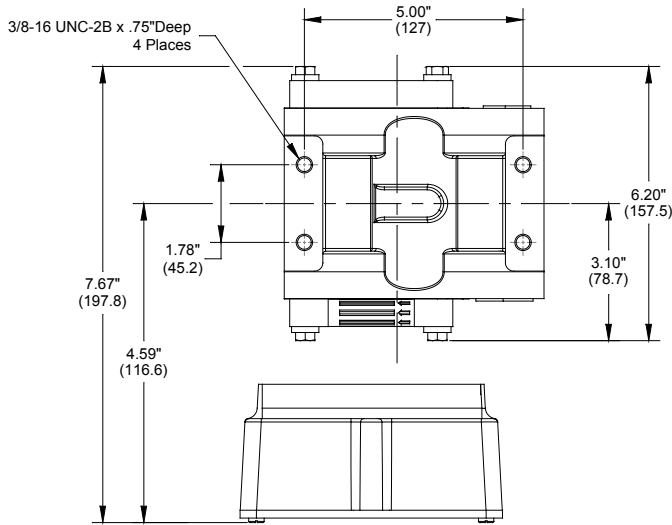

Description: Pressure filters ensure the most positive type of filtration and provide clean fluid for sensitive pressure line components.

- 70 gpm (264.9 lpm)
- Maximum Pressure: 6000 psi (413 bar)
- By-Pass Cracking Pressure: 60 psi (4 Bar)
- Buna-N Seals Standard
- SAE O-Ring & SAE 4-Bolt Code 61 Flange Ported
- Visual Indicator Standard

• Electrical Indicator Optional

Max Temp: 250F/121C

Set: 40 psi / 276kPa

Voltage: 120 VAC / 28 VDC

Current: 250 mA

Circuit: Normaly Open (RED)

Normaly Closed (BLUE)

Common (WHITE)

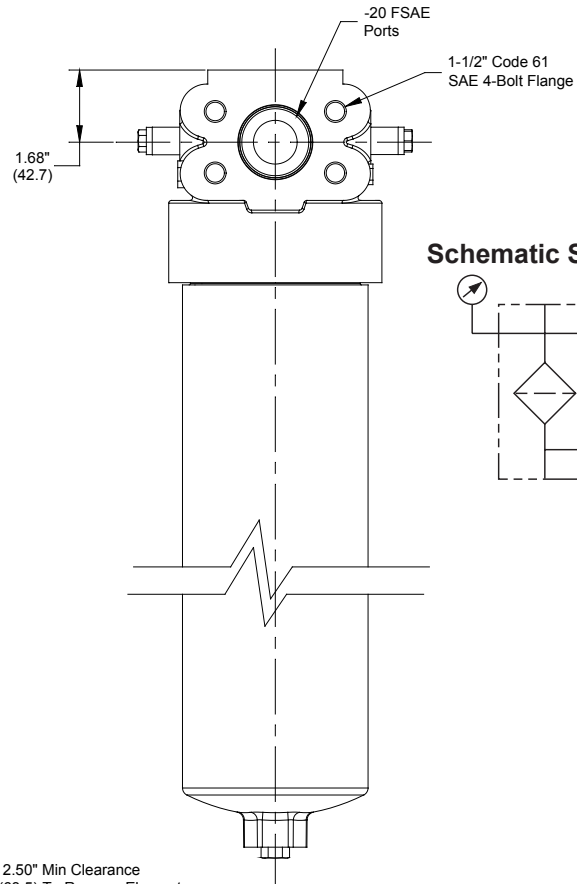
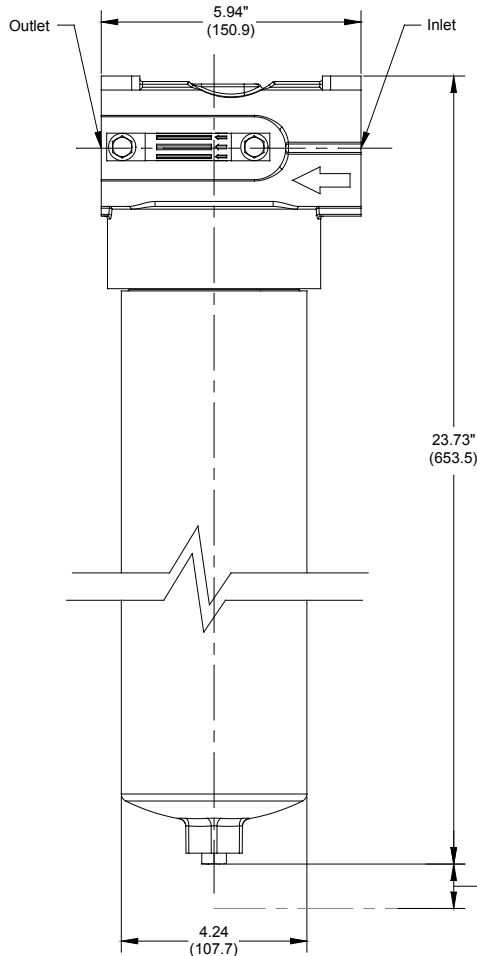

Power Unit Accessories
 NFPA/JIC STYLE AND L-SHAPED POWER UNITS
 Pressure Filter - 70 gpm (264.9 lpm)

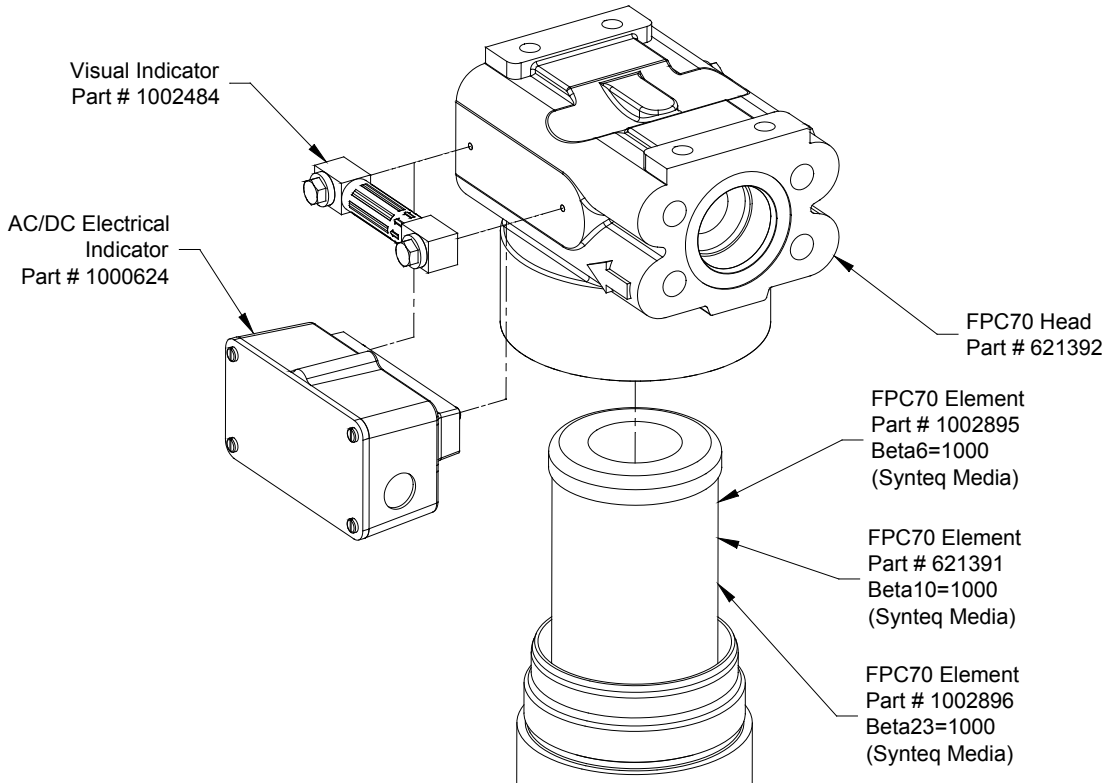

FPC70 ELEMENT ONLY

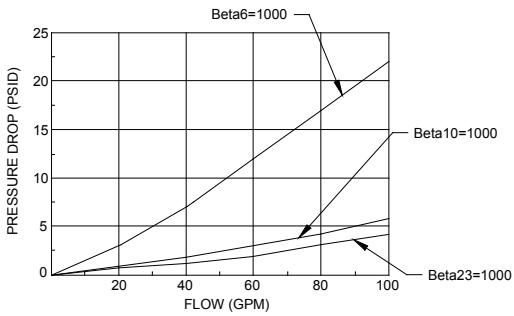

FPC70 HOUSING ONLY

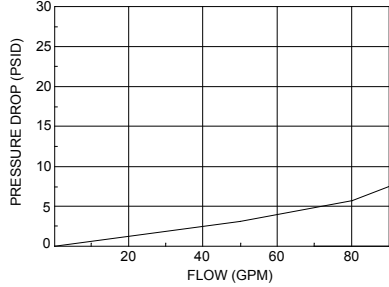

Model Code

Filter Pressure Flow

F P **70**

Indicator

Code	Description
C	Visual - #1002484
E	Electrical - #1000624

Power Unit Accessories

ALL POWER UNITS

Inlet Strainers



Dimensions shown in: Inches (± .125)
(millimeters (± 1 mm))

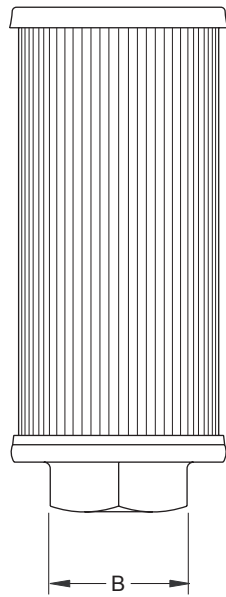

Schematic Symbol

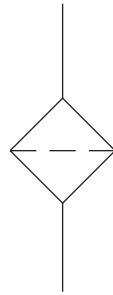

Description: Inlet Strainers are used to keep contaminants from entering the hydraulic system.

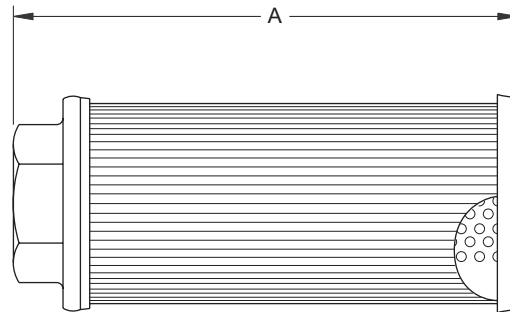
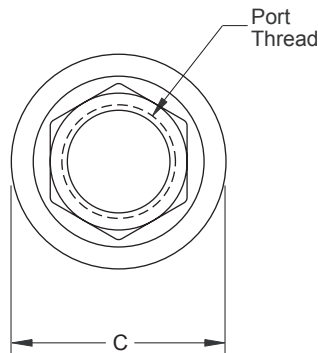

Model Code

Strainer

STR

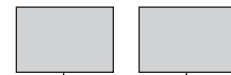

Port Size

Code
08
16
20
24
32
40
48

Mesh

Code
60
100

Dimensions and Specifications

Model Code	A	B	C	Thread	gpm (lpm)	Area	Micron	Part No.
STR-16-60	5.75 (146.0)	1.63 (41.4)	3.19 (81.0)	1" NPT	10 (37.8)	125 sq. in. (806.5 cm ²)	262	148688
STR-20-60	7.38 (187.5)	2.00 (50.8)	3.19 (81.0)	1-1/4" NPT	20 (75.7)	162 sq. in. (1045.2 cm ²)	262	148690
STR-24-60	9.13 (231.9)	2.25 (57.1)	4.19 (106.4)	1-1/2" NPT	30 (113.5)	310 sq. in. (2.88 m ²)	262	148692
STR-32-60	9.75 (247.6)	2.75 (69.8)	4.19 (106.4)	2" NPT	50 (189.2)	340 sq. in. (3.16 m ²)	262	148694
STR-40-60	12.50 (317.5)	3.25 (82.6)	5.19 (131.8)	2-1/2" NPT	75 (283.9)	400 sq. in. (3.72 m ²)	262	128802
STR-48-60	10.30 (261.6)	4.00 (101.6)	5.00 (127.0)	3" NPT	150 (567.7)	920 sq. in. (8.55 m ²)	262	954253
STR-08-100	3.10 (78.7)	1.13 (28.7)	2.70 (68.6)	1/2" NPT	5 (18.9)	62 sq. in. (400.0 cm ²)	149	944057
STR-16-100	2.13 (54.1)	1.63 (41.4)	3.19 (81.0)	1" NPT	10 (37.8)	14.7 sq. in. (95.2 cm ²)	149	914469
STR-16-100	6.00 (152.4)	1.88 (47.8)	1.50 (38.1)	1" NPT	10 (37.8)	68 sq. in. (441.0 cm ²)	149	120806
STR-16-100	5.75 (146.0)	1.63 (41.4)	3.19 (81.0)	1" NPT	10 (37.8)	125 sq. in. (806.5 cm ²)	149	148689
STR-20-100	7.38 (187.5)	2.00 (50.8)	3.19 (81.0)	1-1/4" NPT	20 (75.7)	162 sq. in. (1045.2 cm ²)	149	148691
STR-24-100	9.13 (231.9)	2.25 (57.1)	4.19 (106.4)	1-1/2" NPT	30 (113.5)	310 sq. in. (2.88 m ²)	149	148693
STR-32-100	9.75 (247.6)	2.75 (69.8)	4.19 (106.4)	2" NPT	50 (189.2)	340 sq. in. (3.16 m ²)	149	148695
STR-40-100	12.50 (317.5)	3.25 (82.6)	5.19 (131.8)	2-1/2" NPT	75 (283.9)	400 sq. in. (3.72 m ²)	149	128801
STR-48-100	10.30 (261.6)	4.00 (101.6)	5.00 (127.0)	3" NPT	150 (567.7)	920 sq. in. (8.55 m ²)	149	954052



Power Unit Accessories

ALL POWER UNITS

Inlet Strainers

Strainer Application for Fluid Codes H1 and H5

Power Unit Type	PVR6	Piggyback PVR6 on R20 Rsvr	PVR15	PVR50	HPV6	HPV10-thru HPV-29	Gear Pumps G0.6B30-G3.4B21.5	Gear Pumps G2.0B31.5-G11B27
NFPA/JIC	148691	120806	148695	954052	148691	148695	N/A	N/A
L-Shaped	148691	N/A	148695	954052	148691	148695	N/A	N/A
Little Champ®	148691	N/A	N/A	N/A	N/A	N/A	944057	148689
Low Profile	914469	N/A	N/A	N/A	N/A	N/A	914469	914469

Strainer Application for Fluid Codes H3 and H4

Power Unit Type	PVR6	PVR15	PVR50	HPV6	HPV10-thru HPV-29	Gear Pumps G0.6B30-G3.4B21.5	Gear Pumps G2.0B31.5-G11B27
NFPA/JIC	148690	148694	954253	148690	148694	N/A	N/A
L-Shaped	148690	148694	954253	148690	148694	N/A	N/A
Little Champ®	148688	N/A	N/A	N/A	N/A	944057	148688
Low Profile	914469	N/A	N/A	N/A	N/A	914469	914469

Power Unit Accessories

NFPA/JIC AND L-SHAPED POWER UNITS

Air-to-Oil Heat Exchangers - Return Flow

Description: These Heat Exchangers are designed to be used primarily as a cooling device for return flow.

- Heat Removal Up to 80 HP (59.7 kW)
- Oil Flows to 150 gpm (567.7 lpm)
- Mounting Brackets Included
- SAE Connections
- Three Phase Motors
- Built-In 30 psi (2 bar) By-Pass Valve

Dimensions shown in: Inches (± .125)
 (millimeters (± 1 mm))

Schematic Symbol

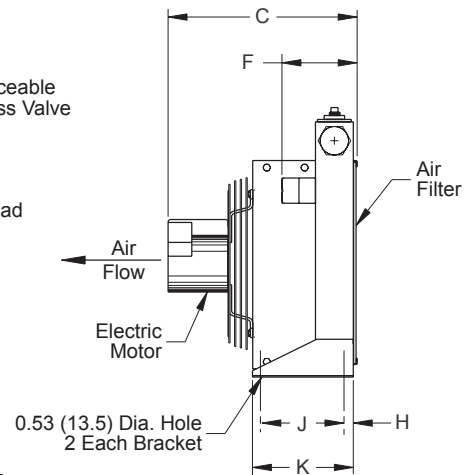
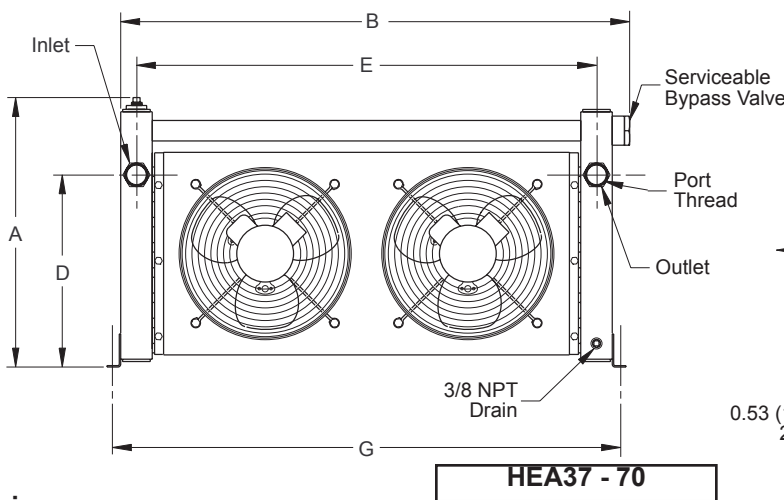
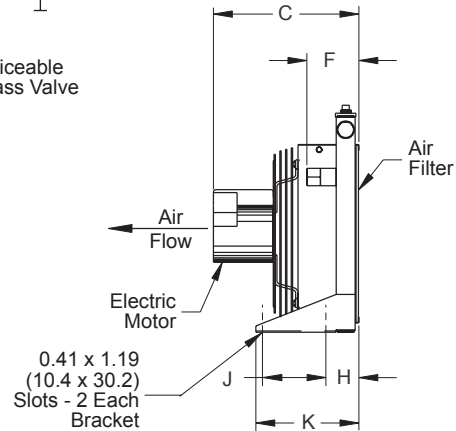
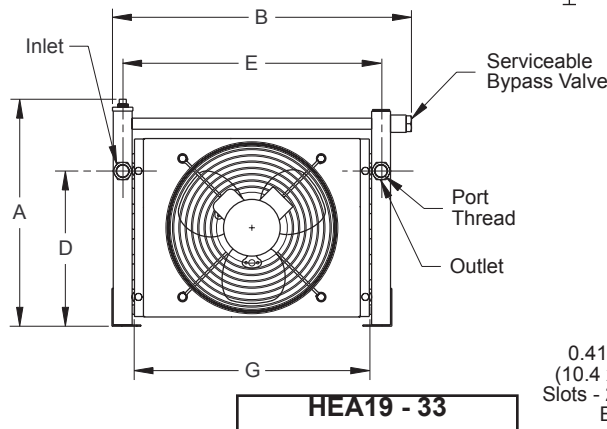
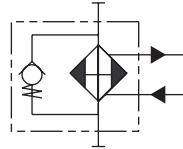

Dimensions

Size	A	B	C	D	E	F	G	H	J	K
HEA19	16.00 (406.4)	16.18 (411.0)	13.08 (332.2)	10.31 (261.9)	15.00 (381.0)	3.05 (77.5)	14.75 (374.6)	2.61 (66.3)	5.00 (127.0)	8.18 (207.8)
HEA22	18.00 (457.2)	23.66 (601.0)	12.19 (309.6)	12.31 (312.7)	20.50 (520.7)	3.05 (77.5)	18.69 (474.7)	2.61 (66.3)	5.00 (127.0)	8.18 (207.8)
HEA24	22.00 (558.8)	26.41 (670.8)	13.19 (335.0)	16.31 (414.3)	23.25 (590.6)	3.05 (77.5)	21.44 (544.6)	2.61 (66.3)	5.00 (127.0)	8.18 (207.8)
HEA33	28.00 (711.2)	31.91 (810.5)	13.19 (335.0)	22.31 (566.7)	28.75 (730.2)	3.05 (77.5)	26.97 (685.0)	2.61 (66.3)	5.00 (127.0)	8.18 (207.8)
HEA37	21.38 (543.1)	40.38 (1025.7)	15.66 (397.8)	15.25 (387.3)	36.50 (927.1)	4.62 (117.3)	40.50 (1028.7)	1.06 (26.9)	6.50 (165.1)	8.31 (211.1)
HEA50	25.38 (644.7)	42.38 (1076.5)	15.62 (396.7)	19.25 (488.9)	38.50 (977.9)	4.68 (118.9)	42.50 (1079.5)	1.12 (28.4)	6.50 (165.1)	8.37 (212.6)
HEA54	33.28 (845.3)	43.38 (1101.9)	17.09 (434.1)	27.25 (692.1)	39.50 (1003.3)	4.89 (124.2)	43.75 (1111.2)	1.87 (47.5)	9.00 (228.6)	12.37 (314.2)
HEA57	39.38 (1000.3)	49.38 (1254.3)	16.72 (424.7)	32.75 (831.8)	45.50 (1155.7)	6.68 (169.7)	49.75 (1263.6)	1.87 (47.5)	9.00 (228.6)	12.37 (314.2)
HEA70	41.25 (1047.7)	52.38 (1330.5)	22.62 (574.5)	34.00 (863.6)	48.50 (1231.9)	8.44 (214.4)	52.75 (1339.8)	1.62 (41.1)	9.00 (228.6)	12.12 (307.8)



Power Unit Accessories

NFPA/JIC AND L-SHAPED POWER UNITS

Air-to-Oil Heat Exchangers - Return Flow

Heat Exchanger Selection Procedure:

Performance curves are based on 100 SUS (20.6 Cs) oil leaving the cooler 40° F. (5° C.) higher than the incoming water temperature used for cooling. This is also referred to as a 40° F. approach temperature. Horsepower removed needs to be modified if the above is not met.

STEP 1: Determine the Heat Load. This will vary with different systems, but typically, coolers are sized to remove 25 to 50% of the input horsepower of the power unit. (Example: 100 HP power unit x .33 = 33 HP heat load. If BTU/hr. is known: $HP = \frac{BTU/hr.}{2545}$)

STEP 2: Determine Approach Temperature. Desired oil leaving cooler °F - Ambient Air Temperature °F = Actual Approach (maximum reservoir temperature).

STEP 3: Determine Curve Horsepower Heat Load. Enter the information from above:

$$\text{Horsepower Heat Load} \times \frac{40}{\text{Actual Approach}}$$

Viscosity Correction = Curve Horsepower (Correction: 50 SUS = .90

100 SUS = 1.00

150 SUS = 1.14

200 SUS = 1.20

STEP 4: Enter curves at oil flow through cooler and curve horsepower. Any curve above the intersecting point will work.

STEP 5: Determine the Oil Pressure Drop.

● = 5 psi (.3 bar) ■ = 10 psi (.7 bar)

▲ = 20 psi (1.4 bar) ✕ = 40 psi (2.8 bar)

Multiply pressure drop from curve by correction factor: 50 SUS = .5

100 SUS = 1.00

150 SUS = 1.50

200 SUS = 2.00

Specifications

Size	Part No.	Port Size	Motor HP	Motor Specifications	Motor rpm
HEA19	600084	SAE-12	1/4 HP (.19 kW)	208-230/460/60/3 1.3/.65 Amps Full Load	1700
HEA22	600085	SAE-12	1/4 HP (.19 kW)	208-230/460/60/3 1.3/.65 Amps Full Load	1700
HEA24	600086	SAE-12	1/4 HP (.19 kW)	208-230/460/60/3 1.3/.65 Amps Full Load	1700
HEA33	600087	SAE-16	1/4 HP (.19 kW)	208-230/460/60/3 1.3/.65 Amps Full Load	1700
HEA37	600088	SAE-20	1/4 HP (.19 kW)	208-230/460/60/3 1.3/.65 Amps Full Load	1700
HEA50	600089	SAE-20	1/4 HP (.19 kW)	208-230/460/60/3 1.3/.65 Amps Full Load	1700
HEA54	600090	SAE-24	1/4 HP (.19 kW)	208-230/460/60/3 1.3/.65 Amps Full Load	1700
HEA57	600091	SAE-32	1/4 HP (.19 kW)	208-230/460/60/3 1.3/.65 Amps Full Load	1700
HEA70	600092	SAE-32	1 HP (.75 kW)	208-230/460/60/3 3.4/1.7 Amps Full Load	1725

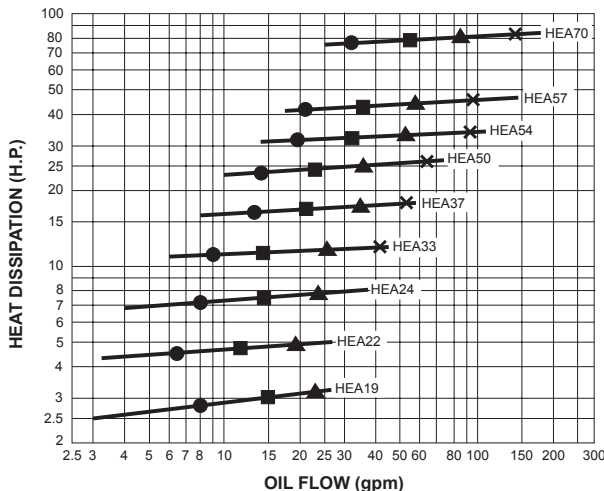

Model Code

HEA
Heat
Exchanger
Air



Size

Code

19
22
24
33
37
50
54
57
70

Power Unit Accessories

ALL POWER UNITS

Air-to-Oil Heat Exchangers - Case Drain



Description: The HEA4 Heat Exchanger is designed to be used primarily as a cooling device for the case drain lines on pressure compensated vane pumps. The cooler must be mounted behind a T.E.F.C. motor to provide the required air movement.

- Utilizes Existing Motor Air Stream
- Protective Steel Case
- 150 psi (10 bar) Pressure Rating
- Gasketed Between Motor and Shell

Dimensions shown in: Inches ($\pm .125$)
(millimeters (± 1 mm))

Schematic Symbol

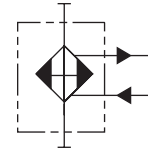

Single Pass

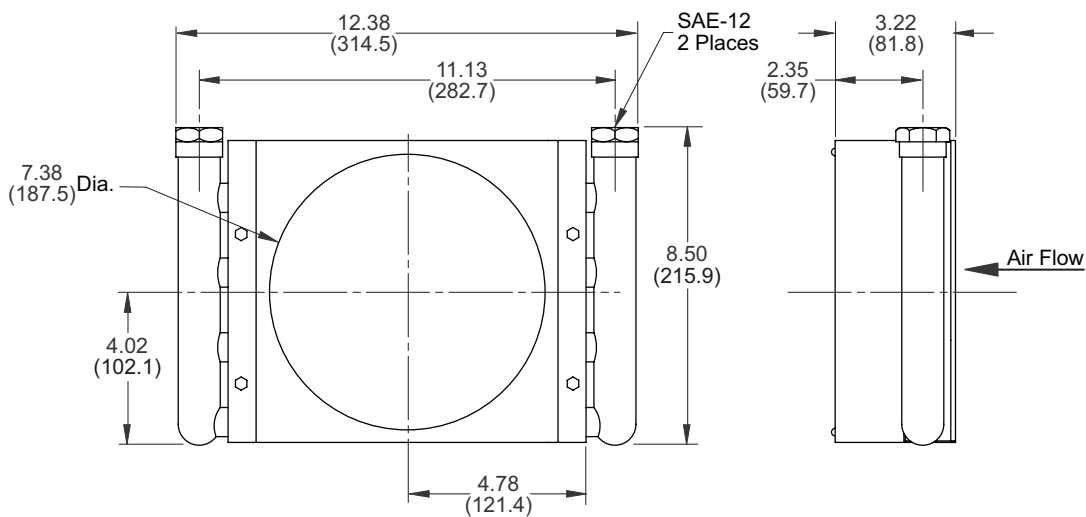

Two Pass

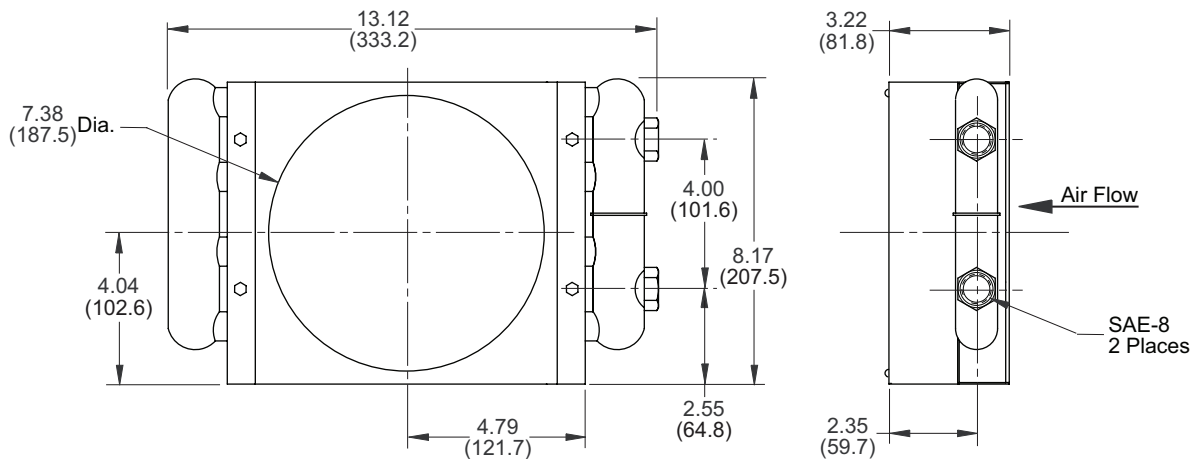

Power Unit Accessories
ALL POWER UNITS
Air-to-Oil Heat Exchangers - Case Drain

Four Pass

Dimensions shown in: Inches (± .125)
 (millimeters (± 1 mm))

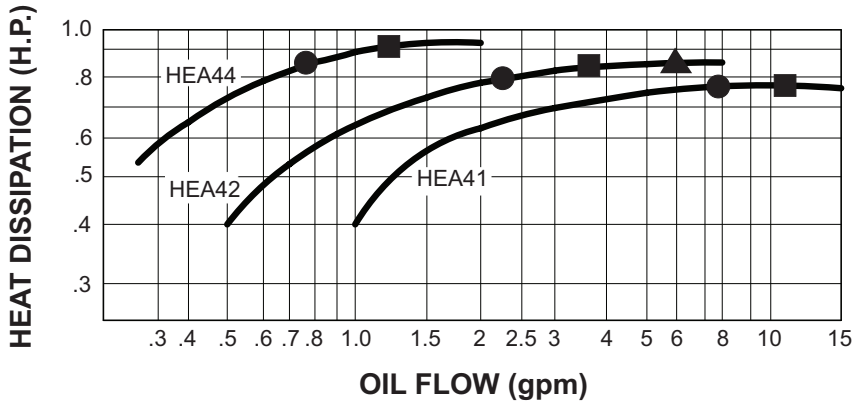
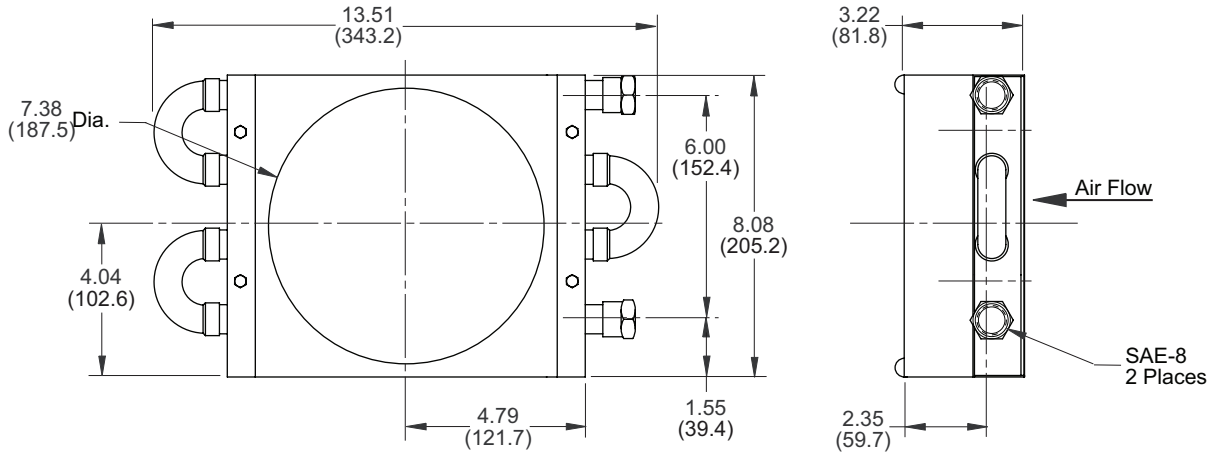

Oil ΔP
 ● = 5 psi
 ■ = 10 psi
 ▲ = 20 psi

Model Code
HEA4
 Heat Exchanger Air

No. of Passes

Code	No. of Passes
1	Single Pass #610861
2	Two Pass #610862
4	Four Pass #610863

Power Unit Accessories

NFPA/JIC AND L-SHAPED POWER UNITS

Water-to-Oil Heat Exchangers



Description: These shell and tube Heat Exchangers are highly efficient and can extend the life of hydraulic components and fluid. The heat exchanger must be placed in the return or low pressure portion of the circuit. Models HEW21, HEW31 and HEW33 have built-in surge cushion.

- Steel Shell
- Copper Tubes
- Aluminum Fins
- HEW11 Has Cast Iron End Bonnets
- HEW21 - HEW33 Have Grey Iron End Bonnets

Dimensions shown in: Inches (± .125)
 (millimeters (± 1 mm))

Schematic Symbol

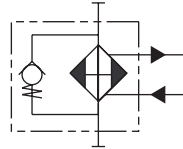

Model Code

HEW
 Heat
 Exchanger
 Water



Size

Code
11
21
31
33

Single Pass

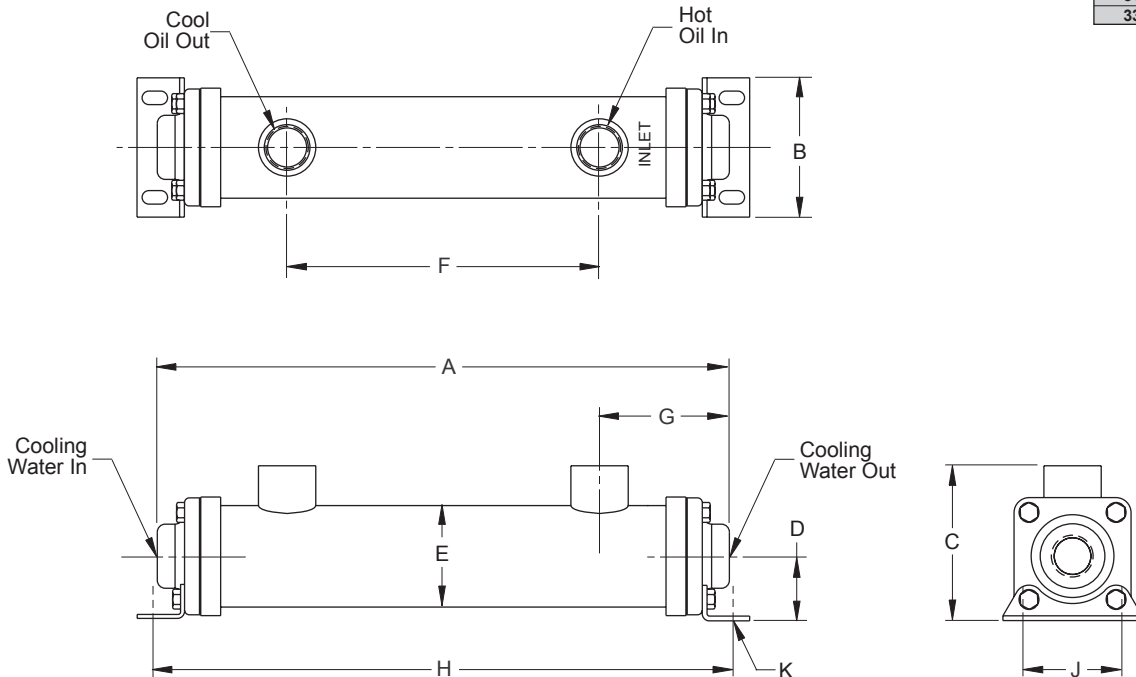

Dimensions

Size	A	B	C	D	E	F	G	H	J
HEW11	11.24 (285.5)	2.62 (66.5)	3.50 (88.9)	1.94 (49.3)	2.13 (54.1)	7.62 (193.5)	1.81 (46.0)	11.01 (279.7)	1.75 (44.4)
HEW21	14.38 (365.3)	3.50 (88.9)	3.90 (99.1)	1.62 (41.2)	2.55 (64.8)	7.85 (199.4)	3.26 (82.8)	14.44 (366.8)	2.50 (63.5)

Dimensions

Size	K
HEW11	1.41 (10.4) Dia.
HEW21	.34 x .62 (8.6 x 15.7) Slot

Power Unit Accessories
 NFPA/JIC AND L-SHAPED POWER UNITS
 Water-to-Oil Heat Exchangers

Two Pass

Dimensions shown in: Inches (± .125)
 (millimeters (± 1 mm))

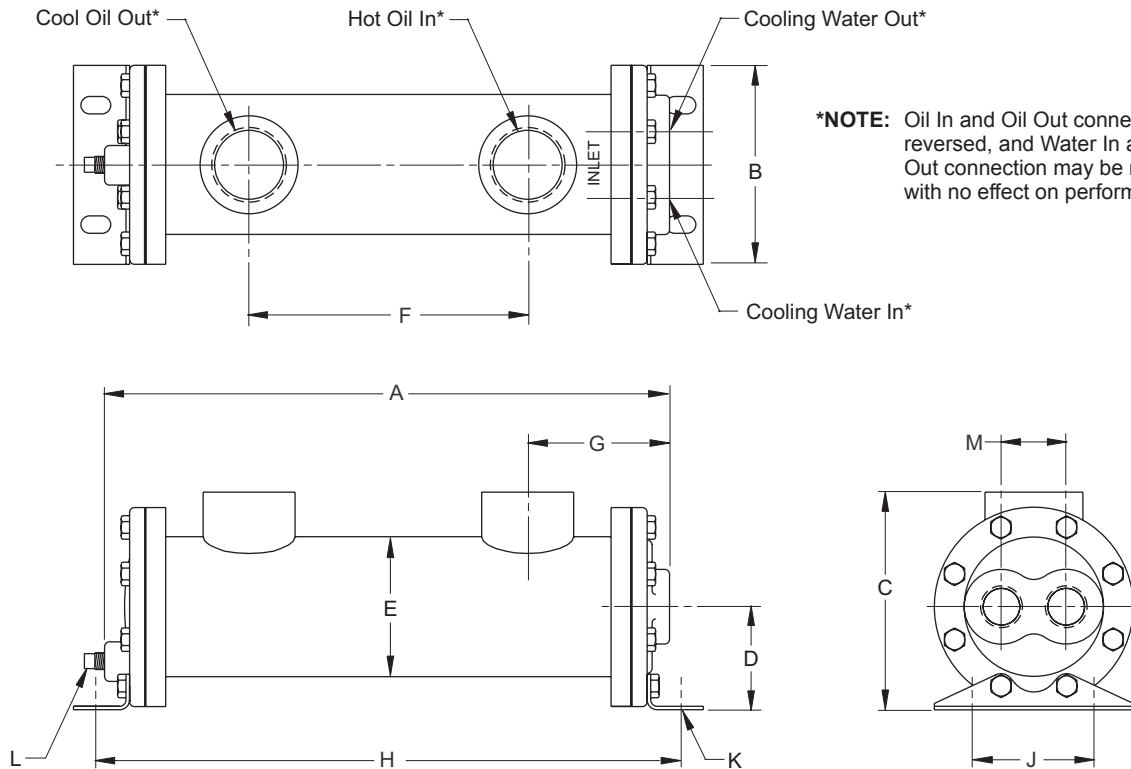

***NOTE:** Oil In and Oil Out connection may be reversed, and Water In and Water Out connection may be reversed with no effect on performance.

Dimensions

Size	A	B	C	D	E	F	G	H	J
HEW31	14.19 (360.4)	5.00 (127.0)	5.47 (138.9)	2.59 (65.8)	3.52 (89.4)	7.00 (177.8)	3.57 (90.7)	14.71 (373.6)	3.00 (76.2)
HEW33	20.19 (512.8)	5.00 (127.0)	5.47 (138.9)	2.59 (65.8)	3.52 (89.4)	13.00 (330.2)	3.57 (90.7)	20.71 (526.0)	3.00 (76.2)

Dimensions

Size	K	L	M
HEW31	.44 x .75 (11.2 x 19.0) Slot	1/4" NPT	1.62 (41.2)
HEW33	.44 x .75 (11.2 x 19.0) Slot	1/4" NPT	1.62 (41.2)

Specifications

Size	Part No.	Water Port	Oil Port	Max. gpm (lpm) Shell (Oil)	Max. gpm (lpm) Tubes (Water)	Max. psi (bar) Shell (Oil)	Max. psi (bar) Tubes (Water)
HEW11	904343	1" NPT	1/2" NPT	9.6 gpm (36.3 lpm)	2.5 gpm (9.5 lpm)	250 psi (17 bar)	150 psi (10.3 bar)
HEW21	133766	3/4" NPT	SAE-12	20 gpm (75.7 lpm)	13 gpm (49.2 lpm)	500 psi (34 bar)	150 psi (10.3 bar)
HEW31	133767	3/4" NPT	SAE-24	70 gpm (264.9 lpm)	12 gpm (45.4 lpm)	500 psi (34 bar)	150 psi (10.3 bar)
HEW33	133768	3/4" NPT	SAE-24	70 gpm (264.9 lpm)	12 gpm (45.4 lpm)	500 psi (34 bar)	150 psi (10.3 bar)

Power Unit Accessories

NFPA/JIC AND L-SHAPED POWER UNITS

Water-to-Oil Heat Exchangers

Heat Exchanger Selection Procedure:

Performance curves are based on 100 SUS (20.6 Cs) oil leaving the cooler 40° F. (5° C.) higher than the incoming water temperature used for cooling. This is also referred to as a 40° F. approach temperature. Horsepower removed needs to be modified if the above is not met.

STEP 1: Determine the Heat Load. This will vary with different systems, but typically, coolers are sized to remove 25 to 50% of the input horsepower of the power unit. (Example: 100 HP power unit x .33 = 33 HP heat load. If BTU/hr. is known: $HP = \frac{BTU/hr.}{2545}$)

STEP 2: Determine Approach Temperature. Desired oil leaving cooler °F - Ambient Air Temperature °F = Actual Approach (maximum reservoir temperature).

STEP 3: Determine Curve Horsepower Heat Load. Enter the information from above:

$$\text{Horsepower Heat Load} \times \frac{40}{\text{Actual Approach}}$$

Viscosity Correction = Curve Horsepower
 (Correction: 50 SUS = .90

100 SUS = 1.00

150 SUS = 1.14

200 SUS = 1.20

STEP 4: Enter curves at oil flow through cooler and curve horsepower. Any curve above the intersecting point will work.

STEP 5: Determine the Oil Pressure Drop.

● = 5 psi (.3 bar) ■ = 10 psi (.7 bar)

Multiply pressure drop from curve by correction factor: 50 SUS = .5

100 SUS = 1.00

150 SUS = 1.50

200 SUS = 2.00

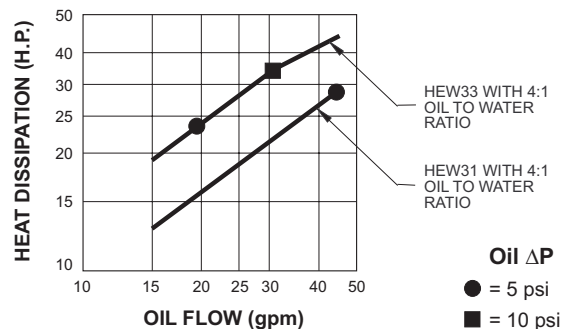
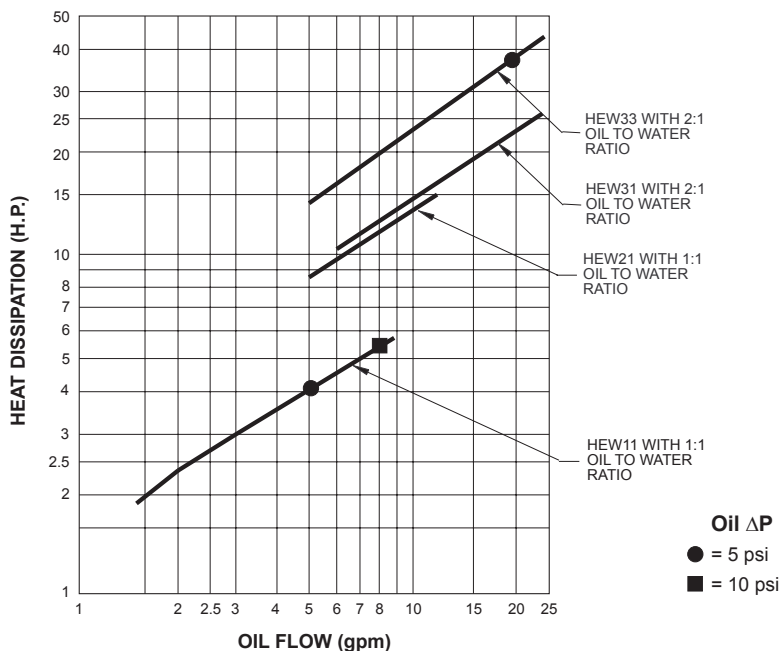

Power Unit Accessories

NFPA/JIC AND L-SHAPED POWER UNITS

Water Modulating Valves

Dimensions shown in: Inches (± .125)
(millimeters (± 1 mm))

Description: A Water Modulating Valve should be placed in the water inlet to the heat exchangers to provide maximum operating efficiency, conserve water usage and eliminate over-cooling the hydraulic oil. The temperature sensor should be located as close as possible to the pump inlet. The sensor may be installed directly into the oil, or into a bulb well.

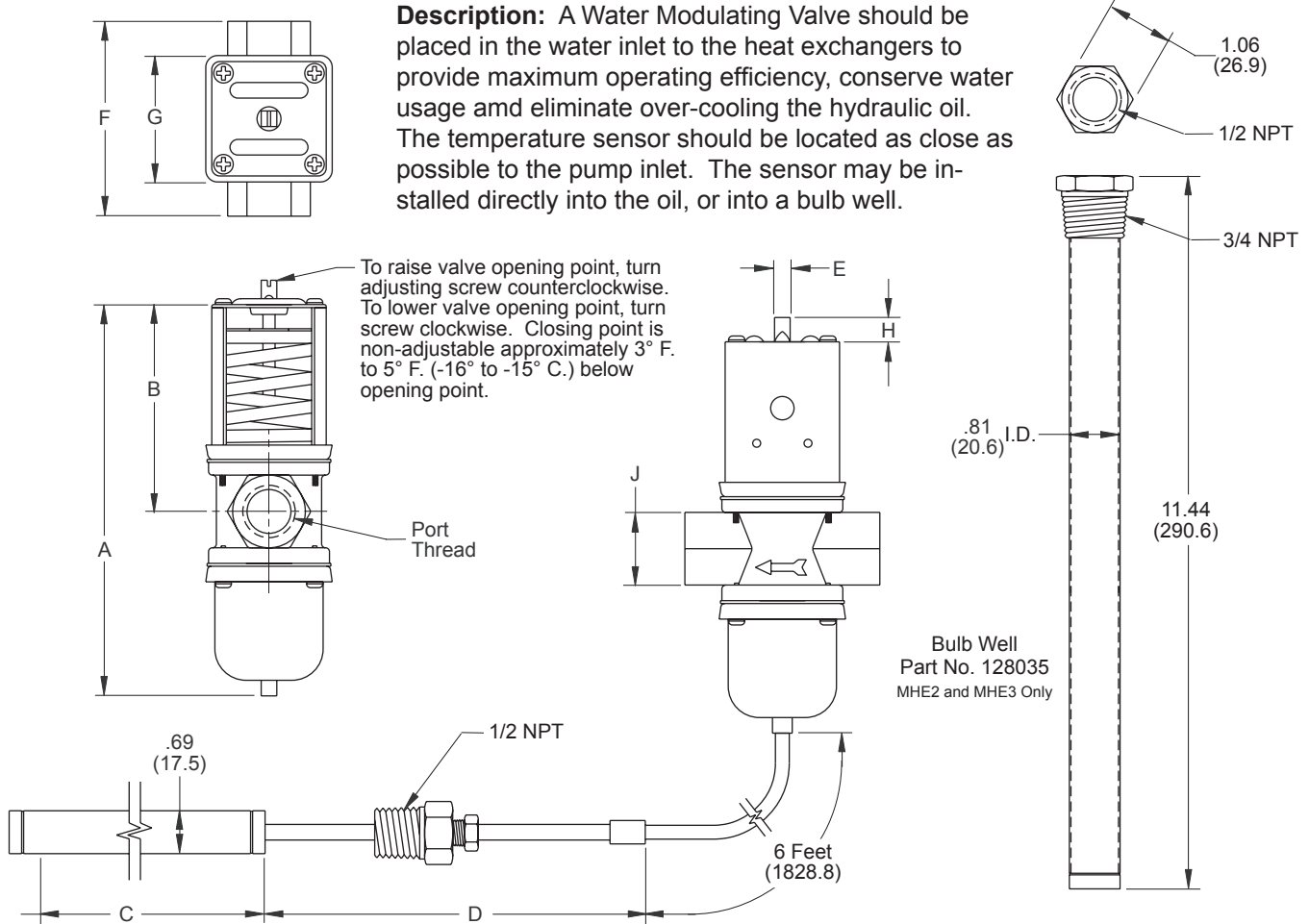

Dimensions

Size	A	B	C	D	E	F	G	H	J
MHE2	6.00 (152.4)	3.31 (84.1)	10.00 (254.0)	6.00 (152.4)	.25 (6.3)	3.13 (79.5)	2.00 (50.8)	.38 (9.5)	1.13 (28.7)
MHE3	6.44 (163.6)	3.75 (95.2)	10.00 (254.0)	6.00 (152.4)	.25 (6.3)	3.44 (87.4)	2.13 (54.1)	.38 (9.5)	1.50 (38.1)
MHE4	9.19 (233.4)	5.50 (139.7)	16.25 (412.7)	3.00 (76.2)	.31 (7.9)	5.00 (127.0)	2.88 (73.2)	.50 (12.7)	2.00 (50.8)

Specifications

Size	Part No.	Port Thread	Temperature Range*	Working Pressure	Water Flow at 55 psi (4 bar)
MHE2	124169	1/2" NPT	75° - 135°F. (24° - 57°C.)	150 psi (10.3 bar)	25 gpm (94.6 lpm)
MHE3	129411	3/4" NPT	75° - 135°F. (24° - 57°C.)	150 psi (10.3 bar)	40 gpm (151.4 lpm)
MHE4	119700	1" NPT	75° - 135°F. (24° - 57°C.)	150 psi (10.3 bar)	55 gpm (208.2 lpm)

*NOTE: Maximum bulb temperature - 20°F. (-7°C.) above temperature range.
Maximum water temperature - 170°F. (77°C.).

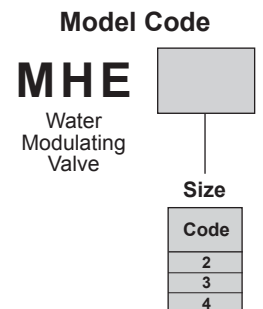
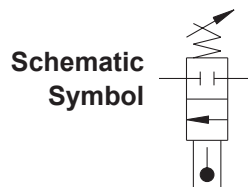

Power Unit Accessories

NFPA/JIC AND L-SHAPED POWER UNITS

"Y" Type Water Strainers



Dimensions shown in: Inches (± .125)
 (millimeters (± 1 mm))

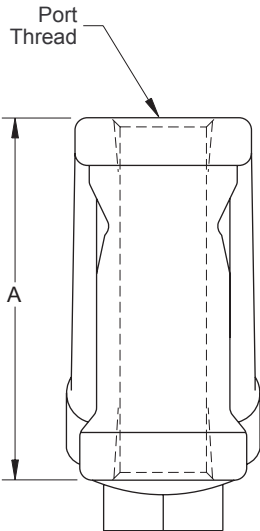

Description: Used to strain foreign matter from water lines. Also provides inexpensive protection for water-to-oil heat exchangers.

- 20 Mesh Screen
- Self-Cleaning By Opening Blowoff Outlet

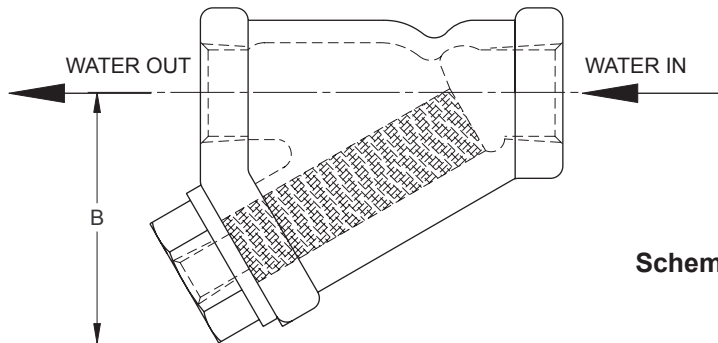
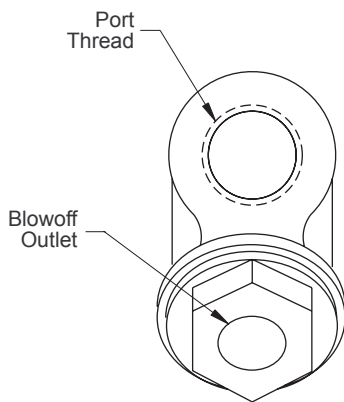

Dimensions

Size	A	B
Y2	3.25 (82.5)	2.13 (54.1)
Y3	3.81 (96.8)	2.50 (63.5)
Y4	4.19 (106.4)	2.56 (65.0)

Schematic Symbol

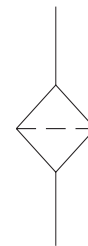

Model Code

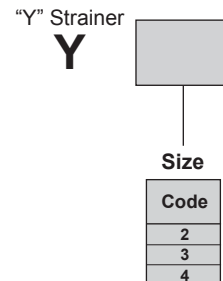

Specifications

Size	Part No.	Port Thread	Blowoff Outlet
Y2	974443	1/2" NPT	1/4" NPT
Y3	974444	3/4" NPT	3/8" NPT
Y4	974445	1" NPT	3/8" NPT

Power Unit Accessories

NFPA/JIC, L-SHAPED AND LITTLE CHAMP® POWER UNITS

Tank Heaters

Dimensions shown in: Inches (± .125)
 (millimeters (± 1 mm))

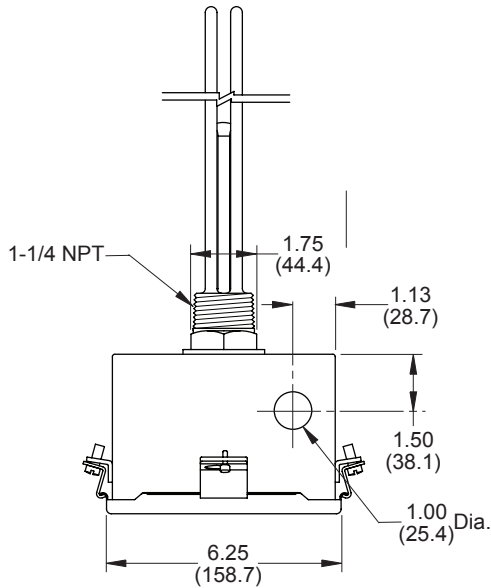

Description: Immersion Heaters are often used to elevate fluid temperature viscosity rating close to that of the operating temperature.

- Dual Voltage 120/240V, 60 Hertz, Single Phase
- NEMA 4 Enclosure
- 30° F. - 100° F. (-1° C. - 38° C.) Thermostat; 25 Amps Maximum
- Steel Elements
- 23 Watts per Square Inch

Dimensions

Reservoir Size	A
10 - 20 Gal. (37.8 - 75.7 liters)	8.75 (222.2)
30 - 60 Gal. (113.5 - 227.1 liters)	25.38 (644.7)
70 - 210 Gal. (254.9 - 794.8 liters)	36.87 (936.5)

Schematic Symbol

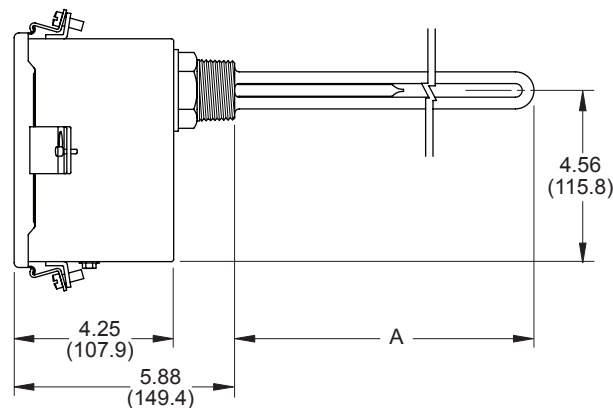
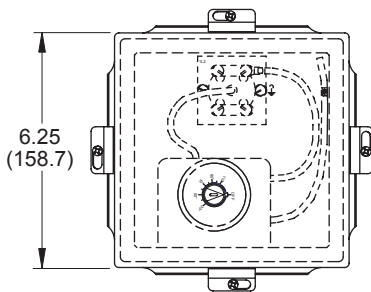
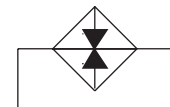

Wiring Diagrams

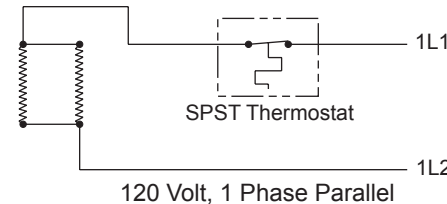
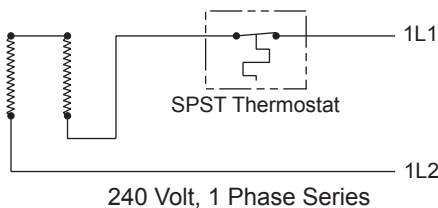

Specifications

Code	Part No.	Application	Watts	Current Draw	
				120 Volts	240 Volts
TH	914840	10 - 20 Gal. (37.8 - 75.7 liters)	700	6 Amps	3 Amps
	914841	30 - 60 Gal. (113.5 - 227.1 liters)	2000	16.7 Amps	8.35 Amps
	914842	70 - 210 Gal. (254.9 - 794.8 liters)	3000	25 Amps	12.5 Amps

Model Code

Tank Heater

TH

Power Unit Accessories

NFPA/JIC AND L-SHAPED POWER UNITS

Pressure Switch

Dimensions shown in: Inches (± .125)
 (millimeters (± 1 mm))

Description: Pressure Switches are used to sense the pressure in a fluid line and control other devices such as electrical components, i.e. valves, motor start/stop switches, alarms, warning lights and programmable logic circuits.

- UL Listed, CSA Certified
- 303 Stainless Steel Piston
- 125 to 3000 psi (9 to 207 bar) Adjustable
- 40 to 180 psi (3 to 12 bar) Deadband
- 10,000 psi (690 bar) Proof Pressure
- SPDT N.O. or N.C. Switch
- 15 Amp, 125/250/480 VAC Resistive
- 1.5% Set Point Repeatability

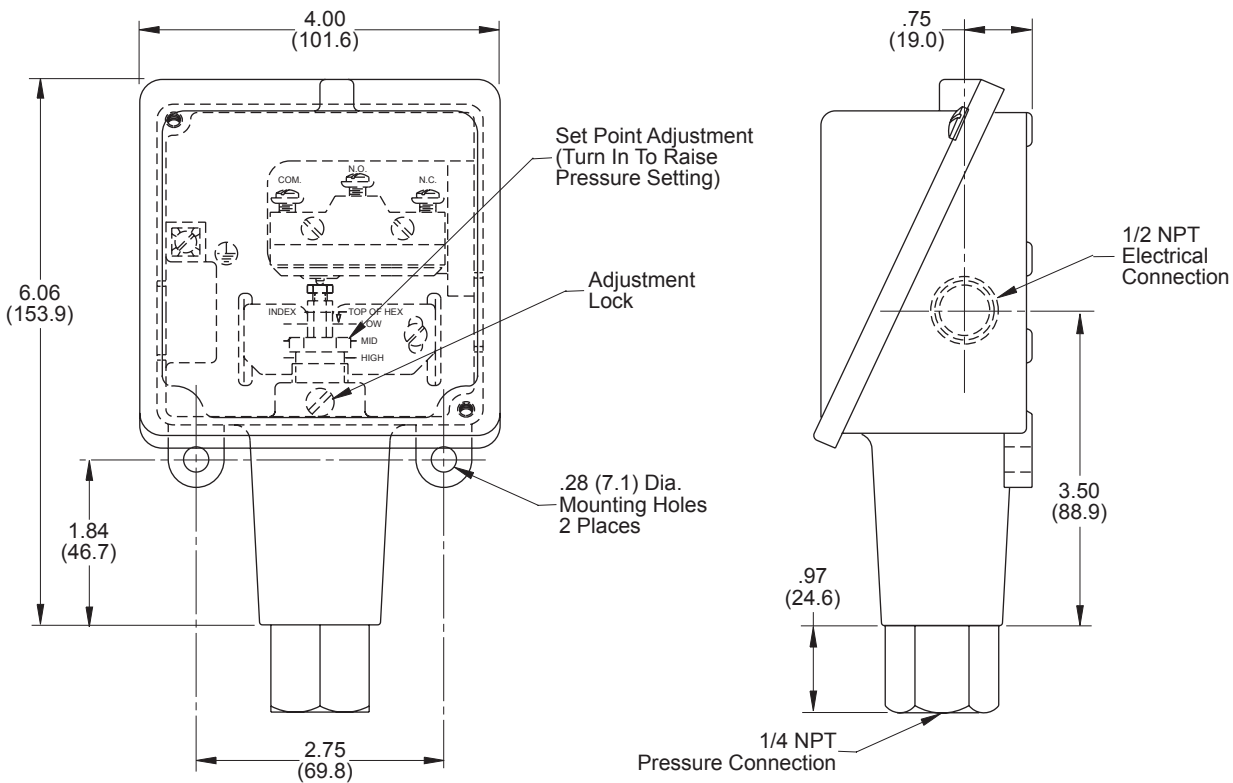
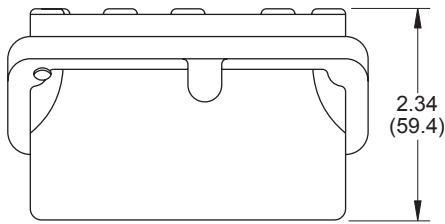

Schematic Symbol

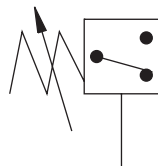

Model Code

Press. Switch Size

PS 1

Part No. 914861

Power Unit Accessories

NFPA/JIC AND L-SHAPED POWER UNITS

Temperature Switch

Dimensions shown in: Inches (± .125)
 (millimeters (± 1 mm))

Description: Temperature Switches sense the hydraulic oil temperature and control other devices such as warning lights, cooling fan motors and emergency shutdown.

- UL Listed, CSA Certified
- NEMA 4 Enclosure
- 30°F. - 250°F. (-1°C. - 121°C.) Adjustable
- 300° (149°C.) Maximum Temperature
- SPDT N.O. or N.C. Switch
- 15 Amp, 125/250/480 VAC Resistive
- 1% of Range Deadband
- 1/2" NPT Electrical Connection

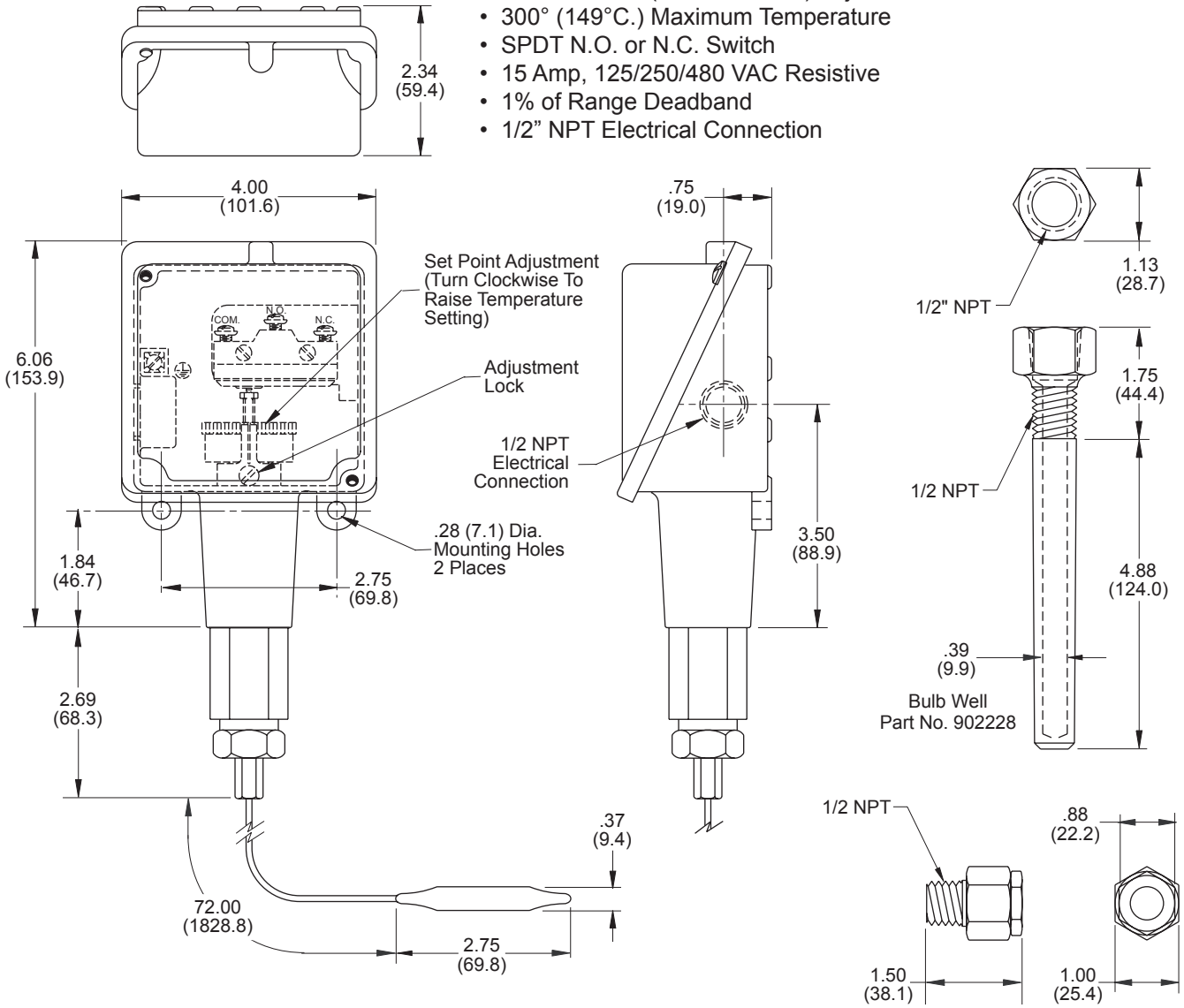

Schematic Symbol

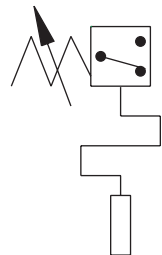

Model Code

Temp. Switch Size

TS 1

Part No. 914862

Split Nut Part No. 904494

Power Unit Accessories

NFPA/JIC, L-SHAPED AND LITTLE CHAMP® POWER UNITS Level/Temperature Switches

Dimensions shown in: Inches (± .125)
 (millimeters (± 1 mm))

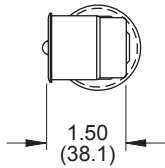

Description: Combination Temperature Switch monitors both liquid level and temperature. It can be wired direct or through relays to operate electric valves such as starters, alarms, etc.

- Junction Box
- Nylon Float
- Actuation Temperature at 140°F. (60°C.)
- Float Can Be Rotated 180° to act as a N.O. Switch

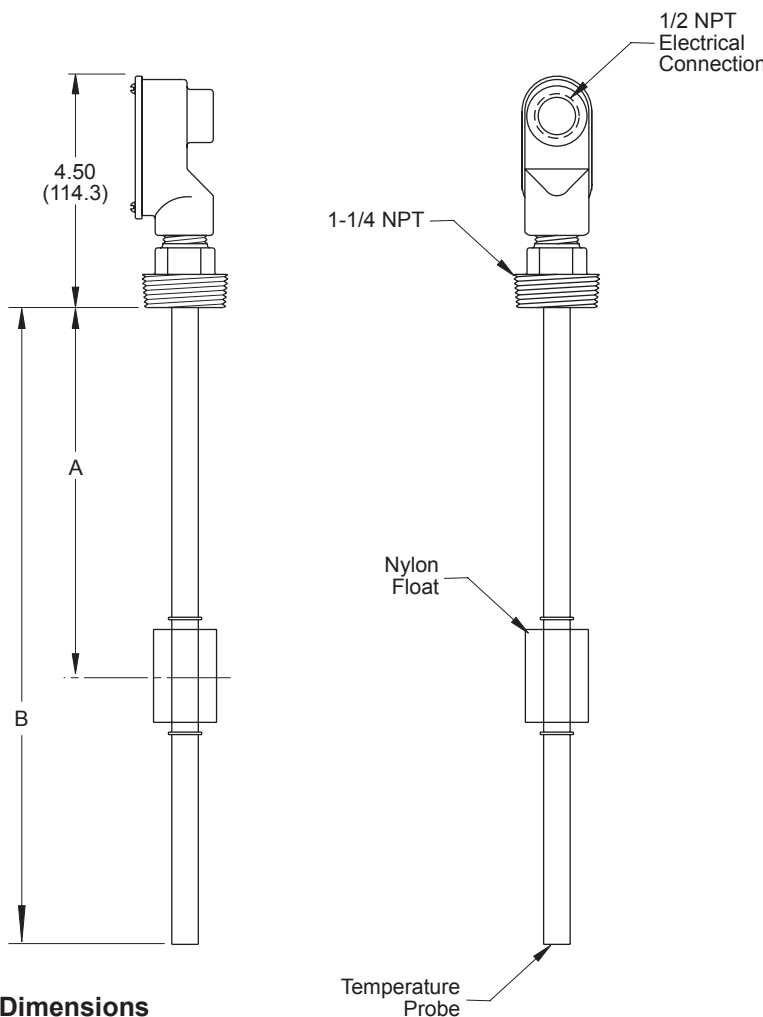

Rating
 Level - .84 Amps @ 120 VAC
 Temperature - 4.0 Amps @ 120 VAC

Schematic Symbol

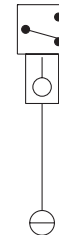

Wiring Diagrams

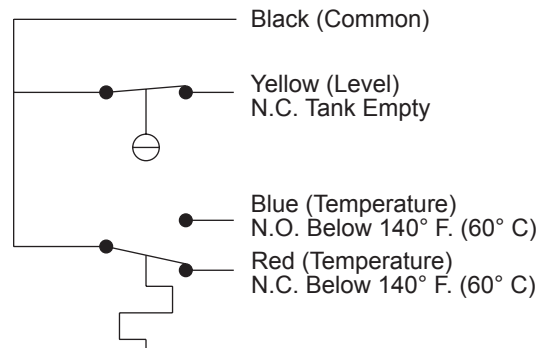

Model Code

Level Temperature Switch

LT -

Float Depth

Dimensions

Code	Part No.	Reservoir Size*	A	B
LT	600636	W10 Gal. (37.9 liters)	3.50 (88.9)	7.25 (184.2)
	621323	R10 / R20 Gal. (37.9 / 75.7 liters)	6.00 (152.4)	11.00 (279.4)
	904490	W20/W30/R35 Gal. (132.5 liters)	7.00 (177.8)	12.00 (304.8)
	904160	R50-R90 Gal. (189.3 - 340.7 liters)	9.00 (228.6)	14.00 (355.6)
	611798	10V - 40V Gal. (37.9 - 151.4 liters)	10.00 (254.0)	15.00 (381.0)
	904161	R130/R210 Gal. (492.1/794.9 liters)	12.00 (304.8)	17.00 (431.8)
	904162	R160 Gal. (605.6 liters)	16.00 (406.4)	21.00 (533.4)

Code	Float Depth
3.5	3.50 (88.9)
6	6.00 (152.4)
7	7.00 (177.8)
9	9.00 (228.6)
10	10.00 (254.0)
12	12.00 (304.8)
16	16.00 (406.4)

*NOTE: Dimensions shown are for the NFPA/JIC, Little Champ, & Low Profile Style Power Units. For L-Shaped Power Units, consult factory.

Dimensions shown in: Inches (± .125)
 (millimeters (± 1 mm))

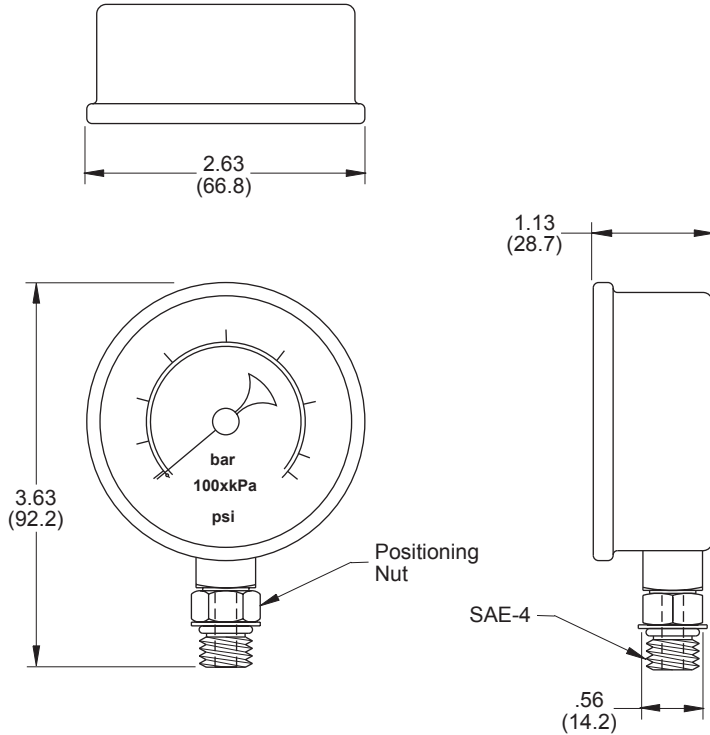

Description: Pressure Gauges are used to indicate hydraulic pressure at a given point in the system.

- 2-1/2 " (63.5 mm) Diameter Face
- Spiral Bourden Tube
- Infragible Polycarbonate Lens
- Stainless Steel Case and Bezel
- Built-In Snubber
- Dual Readout PSI/Bar
- ±1.6% FSD Accuracy
- Temperature Range = 40°F. to 180°F. (4°C. to 80°C.)

Liquid Filled Gauges

- Reduces Pulsation and Vibration Wear
- Weather Tight - No Condensation
- Lengthened Gauge Life
- Continuously Lubricated Internal Parts

Dimensions

Code	Part No.	Pressure Range
G1	964172	0 - 1000 psi (0 - 69 bar)
G1.5	964173	0 - 1500 psi (0 - 103 bar)
G2	964174	0 - 2000 psi (0 - 138 bar)
G3	964175	0 - 3000 psi (0 - 207 bar)
G5	964176	0 - 5000 psi (0 - 345 bar)

*NOTE: Select a gauge which does not allow the operating pressure to exceed 75% of the scale range.

Schematic Symbol



Model Code

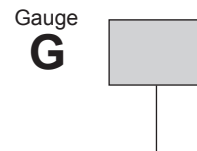

Code	Pressure Range
1	0 - 1000 psi (0 - 69 bar)
1.5	0 - 1500 psi (0 - 103 bar)
2	0 - 2000 psi (0 - 138 bar)
3	0 - 3000 psi (0 - 207 bar)
5	0 - 5000 psi (0 - 345 bar)

Power Unit Accessories

ALL POWER UNITS

Needle Valve



Dimensions shown in: Inches ($\pm .125$)
(millimeters (± 1 mm))

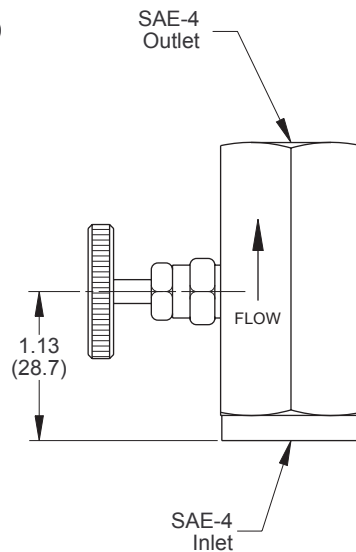
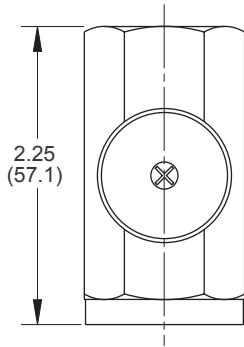
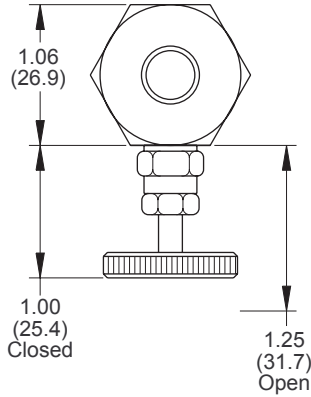

Description: Ideal for pressure gauge shutoff. It can also be used as a safety bleed down for an accumulator.

- Compact Design
- 5000 psi (345 bar) Working Pressure
- SAE O-Ring Ports
- Knurled Knob
- Viton Seals Standard
- Dual Readout PSI/Bar
- -15°F. to 400°F. (-26°C. to 204°C.) Temperature Range

Schematic Symbol

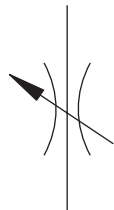

Model Code

Needle Valve

N

Part No. 964086

Power Unit Accessories
NFPA/JIC AND L-SHAPED POWER UNITS
Gauge Isolator

Dimensions shown in: Inches (± .125)
 (millimeters (± 1 mm))

Description: Ideal for extending gauge life. When not reading pressure, the gauge is vented to tank to protect it against pressure pulses from the system.

- Panel Mountable
- Maximum Panel Thickness 5/16" (8 mm)
- 5800 psi (400 bar) Working Pressure
- Viton Seals Standard
- 30°F. to 240°F. (-1°C. to 116°C.) Operating Temperature

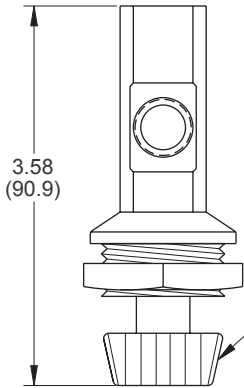

To Operate:
 Push and Hold For Momentary Read.
 Push and Twist Clockwise for
 Continuous Reading.

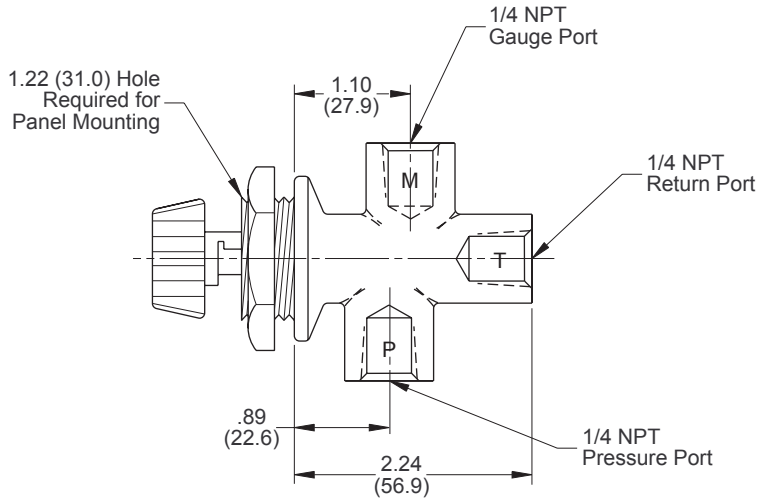
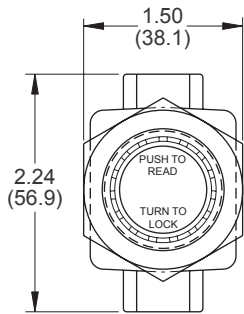

Schematic Symbol

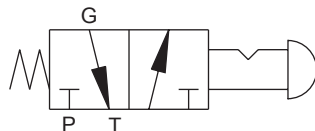

Model Code

Isolator Valve

I V

Part No. 128809

Power Unit Accessories

NFPA/JIC AND L-SHAPED POWER UNITS

Air Bleed Valve

Dimensions shown in: Inches (± .125)
 (millimeters (± 1 mm))

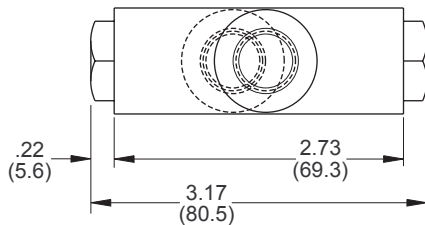

Description: The Air Bleed Valve permits easier pump priming and/or start-up under deadhead conditions. This valve is normally open permitting oil and air (if present) to pass from inlet to outlet and directly back to the tank. Pressure in the spool center section is bled via spool clearance to the no-spring end of the spool. As pressure builds up, it overcomes the spring and shifts the spool to close off the inlet port and allows full pump flow to circuit.

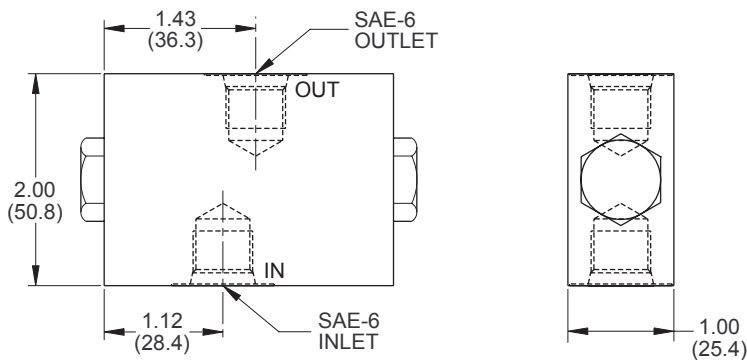

Schematic Symbol

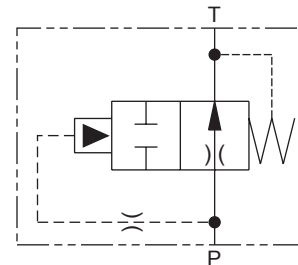

Typical Performance Specifications*

Minimum Flow Rate		8 gpm (30.3 liters)
Minimum	@ 8 gpm (30.3 liters)	500 psi (34 bar)
Operating	@ 15 gpm (56.8 liters)	350 psi (24 bar)
Pressure	@ 50 gpm (189.2 liters)	200 psi (14 bar)
Maximum Operating Pressure		3500 psi (241 Bar)
Minimum Pressure to Hold Closed		150 psi (10 Bar)
Typical	@ 500 psi (34 Bar)	30 sec.
Closing Times	@1000 psi (69 Bar)	10 sec.
Seals		Viton

*NOTE: Data is based on ISO VG 46 oil at 120°F. (49°C.).

Model Code

Air Bleed Valve

AB

Part No. 350755

Power Unit Accessories

NFPA/JIC AND L-SHAPED POWER UNITS

Rapid Response Relief Valves

Dimensions shown in: Inches (± .125)
 (millimeters (± 1 mm))

Description: Rapid Response Relief Valves are especially suited to limiting pressure surges caused by rapidly shifting spool valves, rapidly reversing hydrostatic drives, or the accumulator effect of long lines. They are frequently installed for over-pressure protection in circuits using pressure compensated variable displacement pumps. Systems using Continental Hydraulics vane pumps above 1500 psi (103 bar) may require a rapid response relief valve.

- Steel, Through-Body Design
- SAE O-Ring Work Ports
- 150 to 4500 psi (10 to 310 bar) Adjustable
- Leakage 1 cu. in./1000 psi (16.4 cu. cm/69 bar)

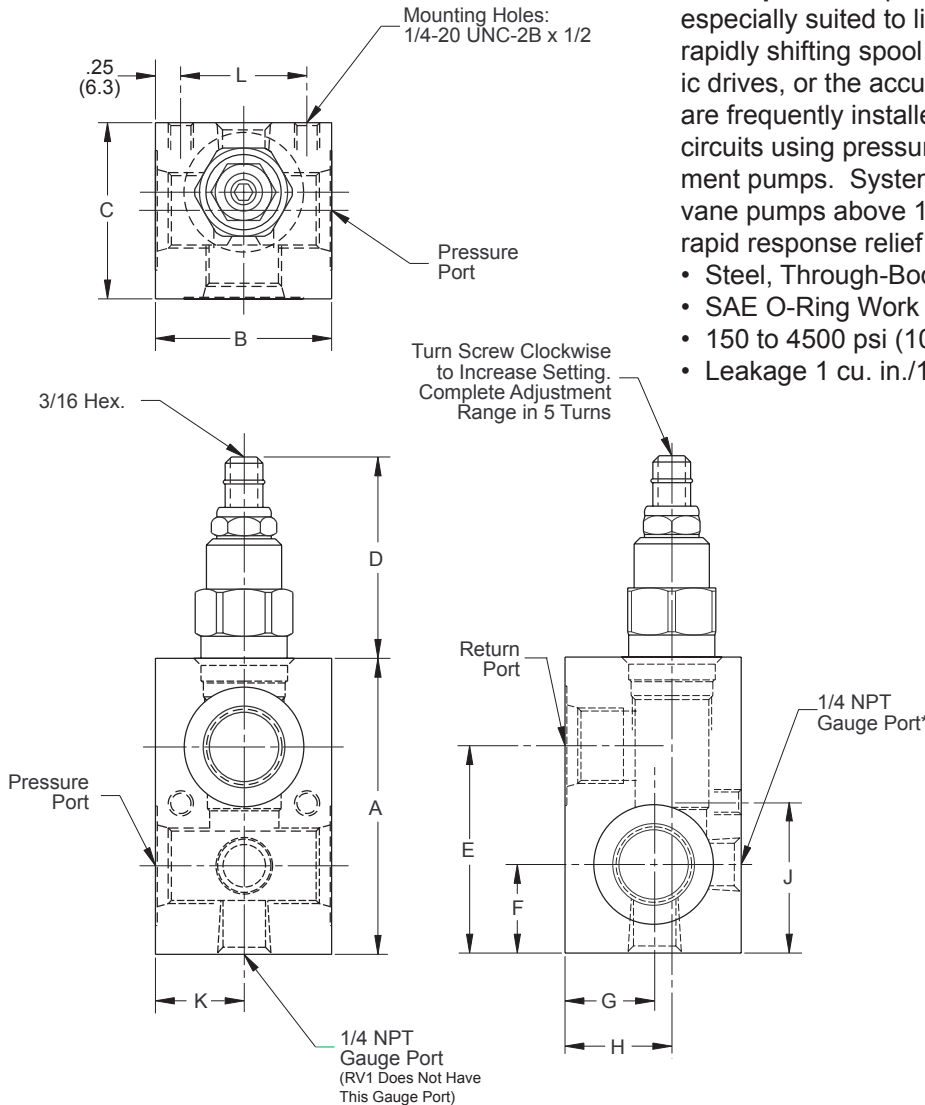

Schematic Symbol

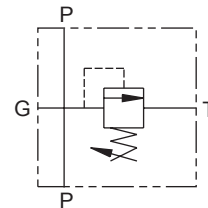

Model Code

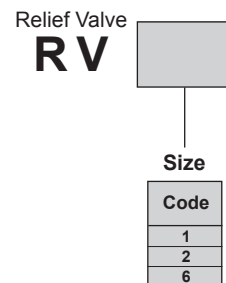

Dimensions

Size	A	B	C	D	E	F	G	H	J	K	L
RV1	2.94 (74.7)	1.75 (44.4)	1.75 (44.4)	2.00 (50.8)	2.06 (52.3)	.88 (22.3)	.88 (22.3)	1.06 (26.9)	1.50 (38.1)	.88 (22.3)	1.25 (31.7)
RV2	3.25 (82.5)	2.00 (50.8)	2.00 (50.8)	2.09 (53.1)	2.19 (55.6)	.75 (19.0)	1.25 (31.7)	1.25 (31.7)	1.62 (41.1)	1.00 (25.4)	1.50 (38.1)
RV6	3.75 (95.2)	2.00 (50.8)	2.50 (63.5)	2.09 (53.1)	2.75 (69.8)	1.00 (25.4)	1.00 (25.4)	1.00 (25.4)	1.88 (47.8)	1.00 (25.4)	1.50 (38.1)

Specifications

Size	Part No.	Port Thread	Working Pressure	Maximum Flow (20 FPS)
RV1	974544	SAE-8	4500 psi (310 bar)	12 GPM
RV2	904640	SAE-12	4500 psi (310 bar)	28 GPM
RV6	904329	SAE-16	4500 psi (310 bar)	50 GPM

Power Unit Accessories

NFPA/JIC AND L-SHAPED POWER UNITS

Check Valves

Dimensions shown in: Inches (± .125)
 (millimeters (± 1 mm))

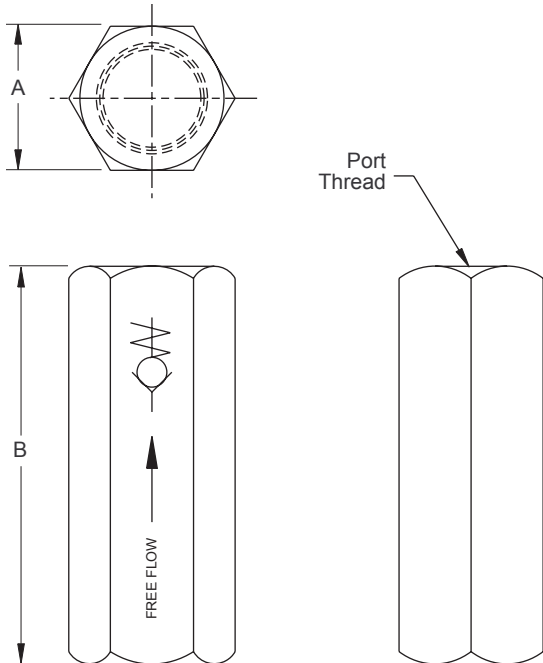

Description: Check Valves allow flow in only one direction. Used for pump isolation or load holding.

- SAE O-Ring Ports
- Precision Machined and Hardened
- Ground Poppet
- Metal-to-Metal seal Design
- Viton Seals Standard

Dimensions

Size	A	B
CV06	1.00 (25.4)	2.60 (66.0)
CV08	1.25 (31.7)	2.87 (72.9)
CV12	1.44 (36.6)	3.46 (87.9)
CV16	1.81 (46.0)	5.00 (127.0)
CV20	2.38 (60.5)	5.63 (143.0)
CV24	2.56 (65.0)	5.63 (143.0)

Schematic Symbol



Specifications

Size	Part No.	Port Thread	Working Pressure	Cracking Pressure
CV06	934705	SAE-6	5000 psi (345 bar)	7 psi (.5 bar)
CV08	934707	SAE-8	5000 psi (345 bar)	7 psi (.5 bar)
CV12	934709	SAE-12	5000 psi (345 bar)	7 psi (.5 bar)
CV16	934711	SAE-16	5000 psi (345 bar)	7 psi (.5 bar)
CV20	934713	SAE-20	5000 psi (345 bar)	7 psi (.5 bar)
CV24	934715	SAE-24	5000 psi (345 bar)	7 psi (.5 bar)

Model Code

Check Valve

CV



Size

Code

06
08
12
16
20
24

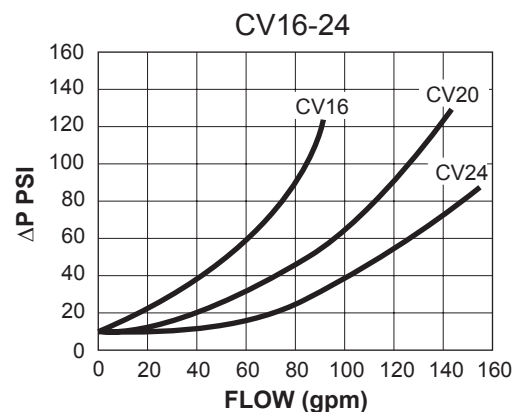
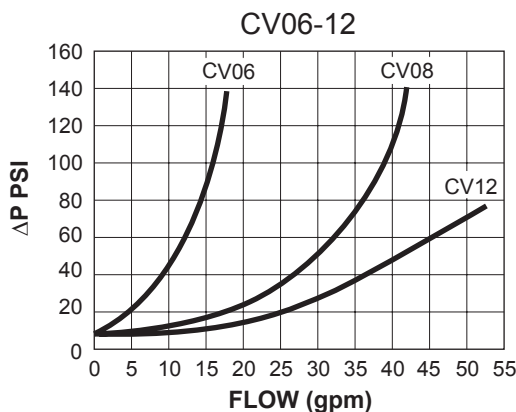

ΔP curves generated using 350 SUS (75.5 Cs) hydraulic oil at a temperature of 86° F. (30° C.).

Power Unit Accessories
 NFPA/JIC AND L-SHAPED POWER UNITS
Ball Valves - High Pressure

Description: Ball Valves are manual valves used as on-off circuit valves. They may also be used as isolating components for system maintenance.

- Full Flow Passage For Unrestricted Fluid Flow
- Direction of Flow Indicated On Control Handle
- 5000 psi (345 bar) Working Pressure
- SAE O-Ring Ported

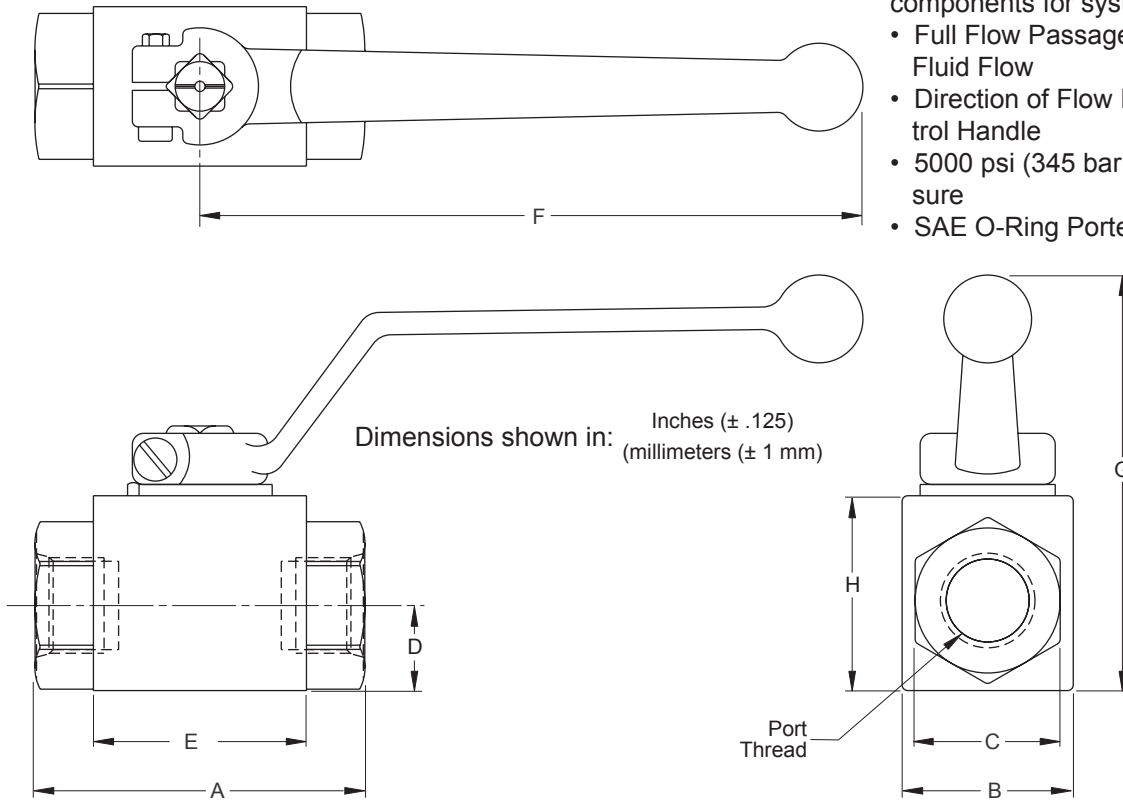

Dimensions

Size	A	B	C	D	E	F	G
BV08	3.23 (82.0)	1.38 (35.1)	1.18 (30.0)	.67 (17.0)	2.00 (50.8)	4.41 (112.0)	3.62 (91.9)
BV12	3.66 (93.0)	1.77 (45.0)	1.61 (40.9)	.95 (24.1)	2.36 (59.9)	7.36 (186.9)	4.45 (113.0)
BV16	4.45 (113.0)	2.17 (55.1)	1.97 (50.0)	1.02 (25.9)	2.76 (70.1)	7.36 (186.9)	4.65 (118.1)
BV20	4.33 (110.0)	2.87 (72.9)	2.36 (59.9)	1.44 (36.6)	2.76 (70.1)	9.45 (240.0)	4.11 (104.4)
BV24	4.49 (114.1)	3.35 (85.1)	2.76 (70.1)	1.67 (42.4)	2.95 (74.9)	9.45 (240.0)	4.11 (104.4)

Specifications

Size	Part No.	Port Thread	Working Pressure
BV08	902559	SAE-8	5000 psi (345 bar)
BV12	902560	SAE-12	5000 psi (345 bar)
BV16	902561	SAE-16	5000 psi (345 bar)
BV20	902562	SAE-20	5000 psi (345 bar)
BV24	902563	SAE-24	5000 psi (345 bar)

Schematic Symbol

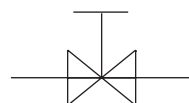

Model Code

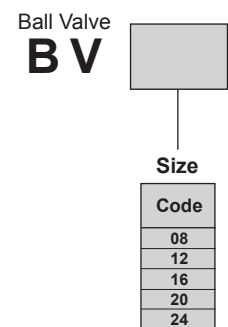

Power Unit Accessories

NFPA/JIC AND L-SHAPED POWER UNITS

Ball Valves - Low Pressure

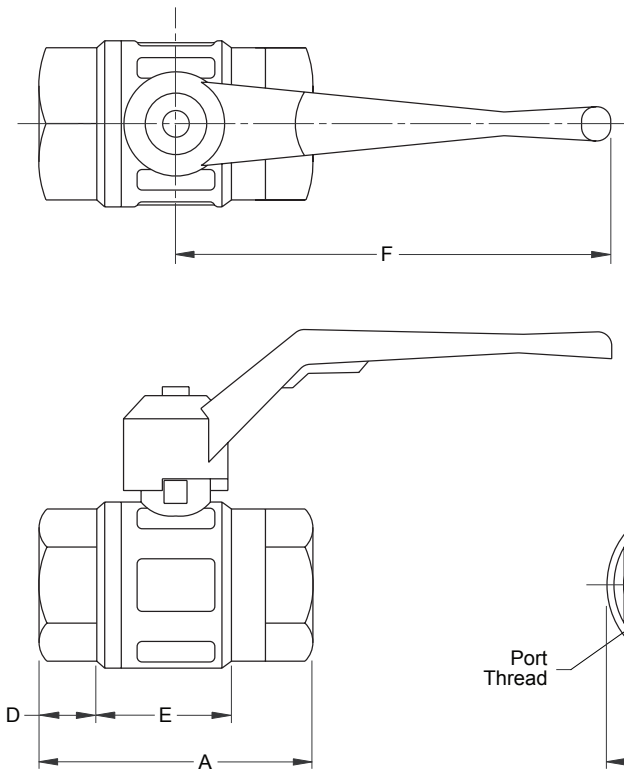

Dimensions shown in: Inches (± .125)
 (millimeters (± 1 mm))

Description: Low Pressure Ball Valves are used for pump inlet shut-off.

- Full Ported
- NPT and SAE Ports
- Teflon Seals (Ball and Stem)
- Hot Pressed Brass Body and Ball
- Chromium Plated Ball and Body

Model Code

Ball Valve **BV**

Size		Thread	
Code		Code	Type
08		N	NPT
12		S	SAE
16			
20			
24			
32			
40			

Dimensions

Size	A	B	C	D	E	F	G
BV08N	2.20 (55.9)	1.28 (32.5)	.59 (15.0)	.53 (13.5)	1.08 (27.4)	3.43 (87.1)	2.47 (62.7)
BV12N	2.46 (62.5)	1.56 (39.6)	.79 (20.1)	.53 (13.5)	1.36 (34.5)	4.41 (112.0)	3.05 (77.5)
BV16N	2.81 (71.4)	1.89 (48.0)	.98 (25.0)	.56 (14.2)	1.61 (40.9)	4.41 (112.0)	3.31 (84.1)
BV20N	3.19 (81.0)	2.32 (58.9)	1.26 (32.0)	.65 (16.5)	1.80 (45.7)	4.41 (112.0)	3.75 (95.2)
BV24N	3.56 (90.4)	2.88 (73.2)	1.57 (39.9)	.67 (17.0)	2.26 (57.4)	5.51 (140.0)	4.52 (114.8)
BV32N	4.13 (104.9)	3.29 (83.6)	1.89 (48.0)	.67 (17.0)	2.72 (69.1)	6.38 (162.1)	5.18 (131.6)
BV40N	5.43 (137.9)	4.35 (110.5)	2.36 (59.9)	.91 (23.1)	3.46 (87.9)	7.87 (199.9)	6.38 (162.1)
BV08S	2.51 (63.8)	1.38 (35.1)	.59 (15.0)	.61 (15.5)	1.31 (33.3)	3.43 (87.1)	2.61 (66.3)
BV12S	2.80 (71.1)	1.60 (40.6)	.79 (20.1)	.66 (16.8)	1.51 (38.4)	4.41 (112.0)	3.10 (78.7)
BV16S	3.37 (85.6)	1.93 (49.0)	.98 (25.0)	.81 (20.6)	1.74 (44.2)	4.41 (112.0)	3.39 (86.1)
BV20S	3.75 (95.2)	2.32 (58.9)	1.26 (32.0)	.89 (22.6)	2.01 (51.1)	4.41 (112.0)	3.75 (95.2)
BV24S	4.22 (107.2)	2.84 (72.1)	1.57 (39.9)	.90 (22.9)	2.42 (61.5)	5.51 (140.0)	4.57 (116.1)
BV32S	4.84 (122.9)	3.29 (83.6)	1.93 (49.0)	1.31 (33.3)	2.76 (70.1)	6.38 (162.1)	5.21 (132.3)

Schematic Symbol

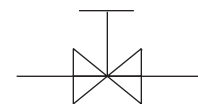

Specifications

NPT Thread

SAE Thread

Size	Part No.	Port Thread	Working Pressure	Size	Part No.	Port Thread	Working Pressure
BV08N	914831	1/2" NPT	600 psi (41 bar)	BV08S	974519	SAE-8	600 psi (41 bar)
BV12N	902485	3/4" NPT	400 psi (28 bar)	BV12S	974520	SAE-12	400 psi (28 bar)
BV16N	902486	1" NPT	400 psi (28 bar)	BV16S	974521	SAE-16	400 psi (28 bar)
BV20N	902487	1-1/4" NPT	400 psi (28 bar)	BV20S	974522	SAE-20	400 psi (28 bar)
BV24N	902488	1-1/2" NPT	400 psi (28 bar)	BV24S	974523	SAE-24	400 psi (28 bar)
BV32N	902489	2" NPT	200 psi (14 bar)	BV32S	974524	SAE-32	200 psi (14 bar)
BV40N	954050	2-1/2" NPT	200 psi (14 bar)				

Power Unit Accessories

NFPA/JIC AND L-SHAPED POWER UNITS

Flow Meters

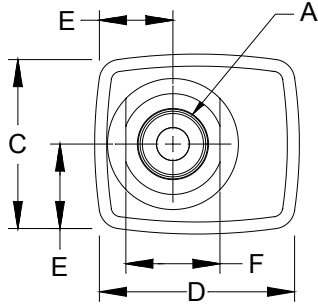

Dimensions shown in: Inches (± .125)
 (millimeters (± 1 mm))

Description: Flow Meters provide up to the minute answers about pump condition and/or systems settings. General design features include rugged construction, operation in any position and accuracy within ± 2%. No special piping required. Flow Meters are relatively insensitive to shock and vibration. They are direct reading and require no electrical connections.

- 360° Rotatable Guard/Scale
- SAE O-Ring Ports
- 2024-T351 Anodized Aluminum Body, Piston and Cone
- Viton Seals Standard
- -20°F. to 400°F. (-29°C. to 204°C.) Continuous Temperature Range

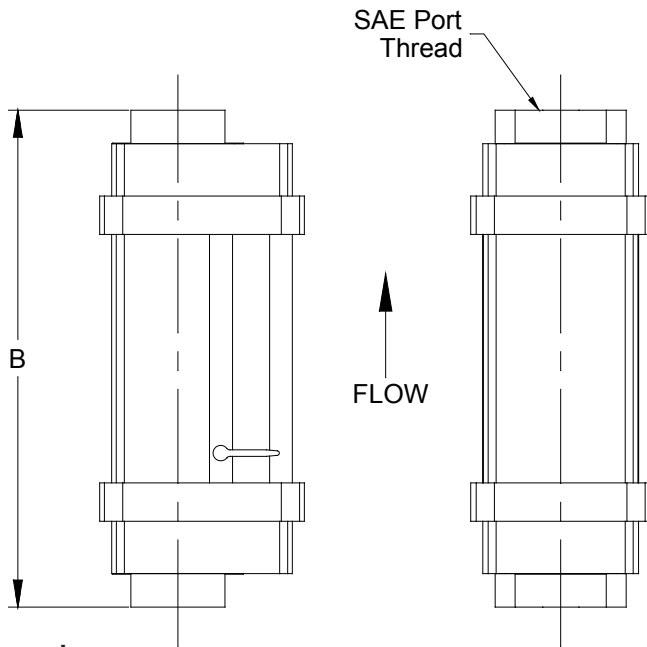

Schematic Symbol

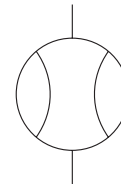

Dimensions

Size	A	B	C	D	E	F
FM1	1/2 (SAE10)	6.60 (168)	2.07 (53)	2.40 (61)	1.04 (26)	1.25 (32)
FM2	7.20 (182.9)	7.20 (183)	2.48 (63)	2.85 (72)	1.24 (32)	1.50 (38)
FM3	12.20 (309.9)	12.20 (310)	4.12 (105)	4.72 (120)	2.06 (52)	2.75 (70)

Model Code

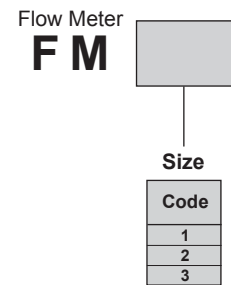

Specifications

Size	Part No.	Port Thread	Working Pressure*	Flow Range	Pressure Drop	
					50% Flow	100% Flow
FM1	934287	SAE-10	3500 psi (241 bar)	1 - 10 gpm (3.9 - 37.8 lpm)	4.00 psi (.28 bar)	9.50 psi (.66 bar)
FM2	934288	SAE-12	3500 psi (241 bar)	3 - 30 gpm (3.9 - 37.8 lpm)	7.00 psi (.48 bar)	16.50 psi (1.14 bar)
FM3	934289	SAE-20	3500 psi (241 bar)	10 - 75 gpm (3.9 - 37.8 lpm)	5.00 psi (.34 bar)	10.50 psi (.72 bar)

*NOTE: Safety Factor - 3:1

Calibrated with 140 SUS (29.7 cS), .876 specific gravity hydraulic oil

Power Unit Accessories

ALL POWER UNITS

Sight Gauges - Internal Thermometer



Dimensions shown in: Inches (± .125)
(millimeters (± 1 mm))

Description: Sight Gauges give you an indication of your current fluid level and temperature.

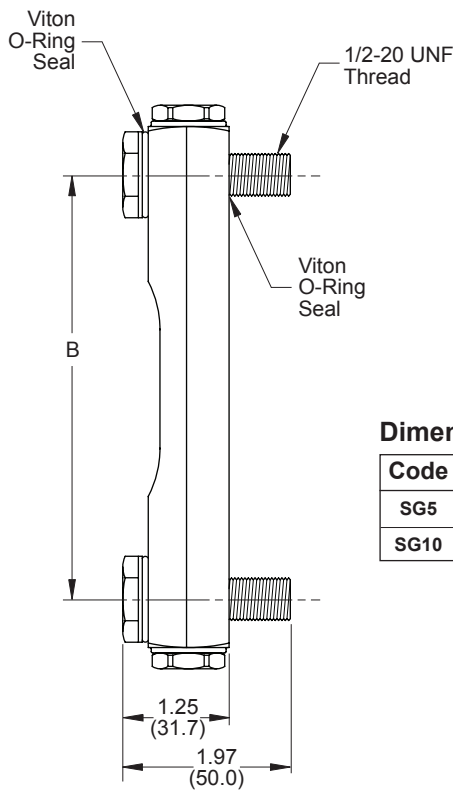
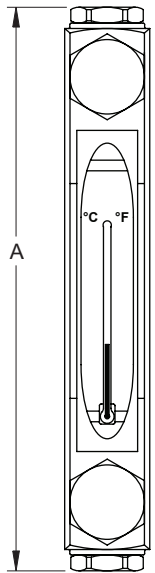
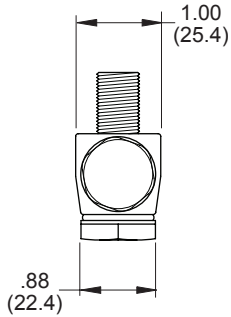

Dimensions

Code	A	B
SG5	6.63 (168.4)	5.00 (127.0)
SG10	11.63 (295.4)	10.00 (254.0)

Specifications

Code	Part No.	Temperature Range	Thermometer Type
SG5	944961	0°F. - 240°F. (0°C. - 116°C.)	Internal (Red)
SG10	944962	0°F. - 240°F. (0°C. - 116°C.)	Internal (Red)

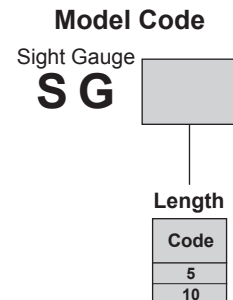

Applications

Power Unit Type	H1 Fluid	H3 Fluid	H4 Fluid	H5 Fluid
NFPA/JIC	944961		944963	
L-Shaped	944961		944963	
Low Profile	944961		944963	
Little Champ®	944961		944963	

Power Unit Accessories
 ALL POWER UNITS
 Sight Gauges - External Thermometer

Dimensions shown in: Inches (± .125)
 (millimeters (± 1 mm))

Description: Sight Gauges give you an indication of your current fluid level and temperature.

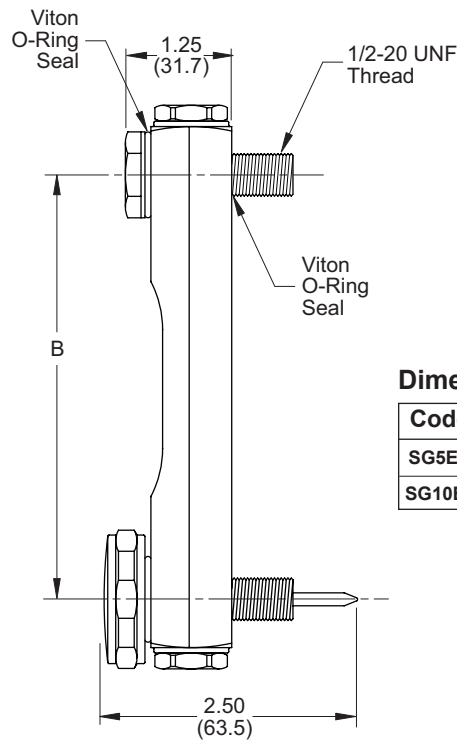
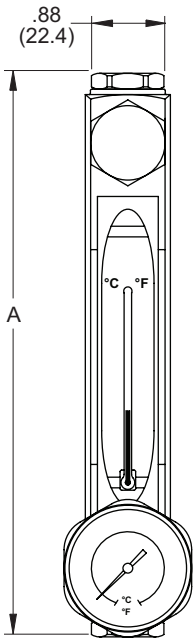
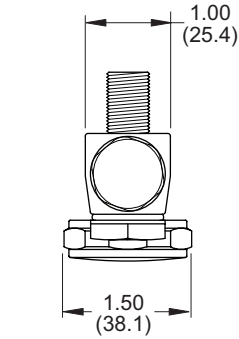

Dimensions

Code	A	B
SG5EX	6.63 (168.4)	5.00 (127.0)
SG10EX	11.63 (295.4)	10.00 (254.0)

Specifications

Code	Part No.	Temperature Range	Thermometer Type
SG5EX	944963	0°F. - 300°F. (0°C. - 149°C.)	External
SG10EX	944964	0°F. - 240°F. (0°C. - 149°C.)	External

Applications

Power Unit Type	H1 Fluid	H3 Fluid	H4 Fluid	H5 Fluid
NFPA/JIC	944961		944963	
L-Shaped	944961		944963	
Low Profile	944961		944963	
Little Champ®	944961		944963	

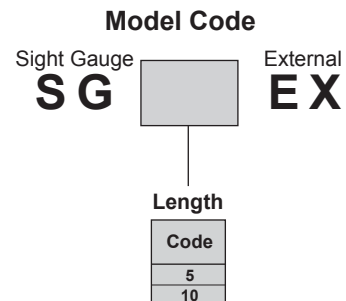

Power Unit Accessories

NFPA/JIC AND L-SHAPED POWER UNITS

Reservoir Drain Valve



Dimensions shown in: Inches (± .125)
(millimeters (± 1 mm))

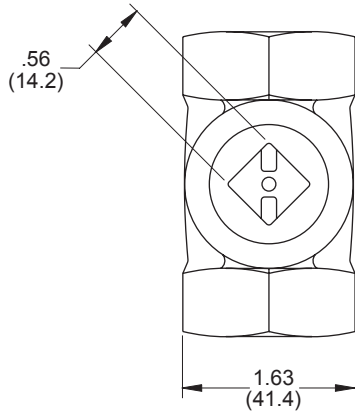

Description: Drain Valves allows the fluid to be removed without disassembling the reservoir. Ball valve design assures leak-free operation.

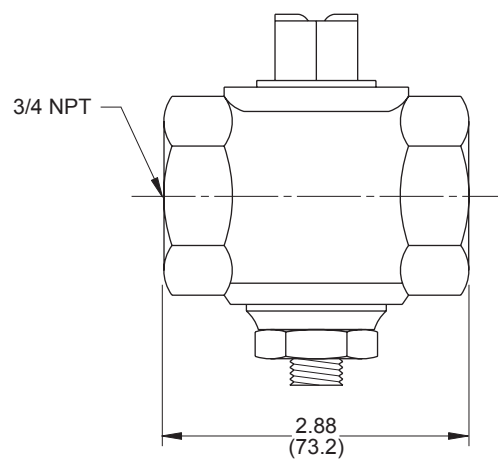
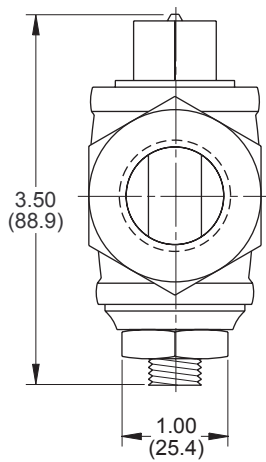

Schematic Symbol

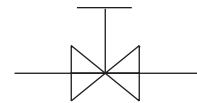

Model Code

Drain Valve

D

Part No. 014630

Power Unit Accessories
 NFPA/JIC AND L-SHAPED POWER UNITS
Magnets

Dimensions shown in: Inches (± .125)
 (millimeters (± 1 mm))

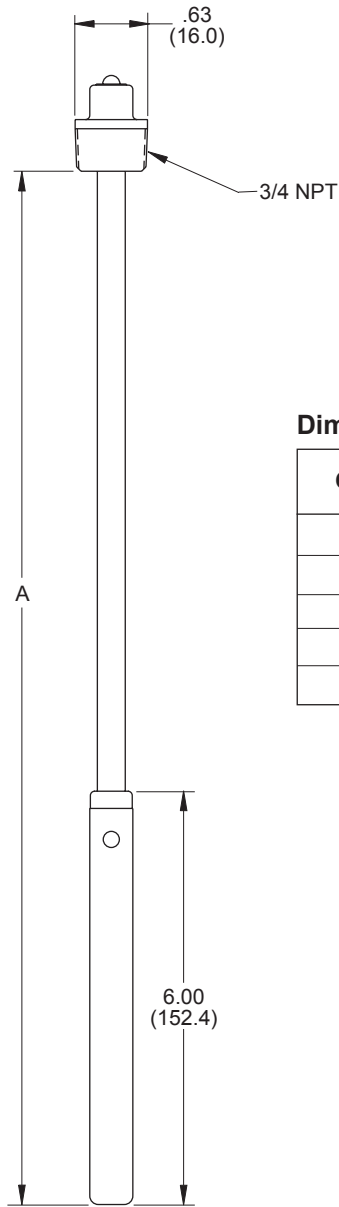

Description: Magnets are used to protect your system from metal partical contamination.

Dimensions

Code	Part No.	Application	Dimension A
M	904429	R10	9.00 (228.6)
M	904430	R20/R35	15.00 (381.0)
M	904431	R50 - R90	19.50 (495.3)
M	904432	R120/R130	25.50 (647.7)
M	904433	R160/R210	33.50 (850.9)

Schematic Symbol

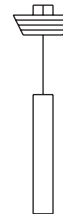

Model Code

Magnet

M

Power Unit Accessories

ALL POWER UNITS

Accumulator - Bladder (Bottom Repairable)



Dimensions shown in: Inches (± .125)
millimeters (± 1 mm)

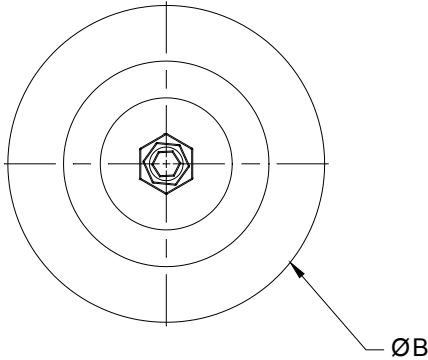

Description: Accumulators are used to assist in flow rates and store fluids under pressure, 3000 PSI max pressure.

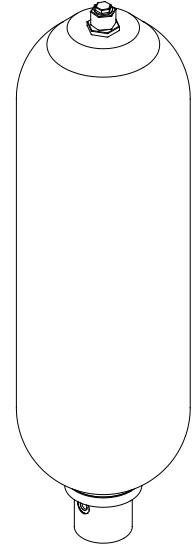

Schematic Symbol

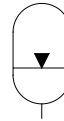

Dimensions

Size	Part No.	Port Size	A	B	C
AC1QT	611873	-12 SAE	12.00 (304.8)	4.50 (114.3)	2.10 (53.3)
AC1	621351	-20 SAE	17.00 (431.8)	6.70 (170.2)	3.50 (88.9)
AC2.5	621274	-24 SAE	21.00 (533.4)	9.00 (228.6)	3.50 (88.9)
AC5	1000055	-24 SAE	33.00 (838.2)	9.00 (228.6)	3.50 (88.9)
AC10	621131	-24 SAE	54.00 (1371.6)	9.00 (228.6)	3.50 (88.9)
AC11	1006937	-24 SAE	60.00 (1524.0)	9.00 (228.6)	3.50 (88.9)
AC15	1000056	-24 SAE	78.00 (1981.2)	9.00 (228.6)	3.50 (88.9)

Accumulators are shipped **WITH NO GAS CHARGE!!**
The Charging and Gauging Assembly Kit is part #1006939.

Model Code

Accumulator
AC

Size

Code	Type
1QT	Quart
1	Gallon
2.5	
5	
10	
15	

*Not Available On The 1 Quart Model

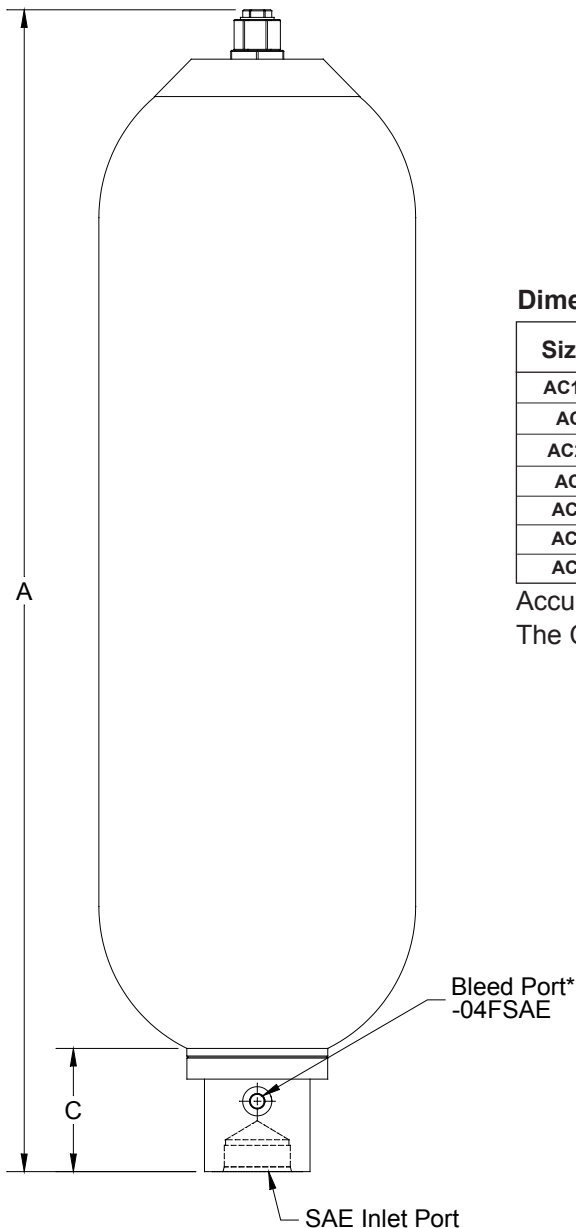

Power Unit Accessories
ALL POWER UNITS
Accumulator Dump Valve

Dimensions shown in: Inches (± .125)
 millimeters (± 1 mm)

Description: Accumulator Dump Valves are used to drain the pressure of the accumulator for safety and maintenance, 3000 PSI max pressure.

Schematic Symbol

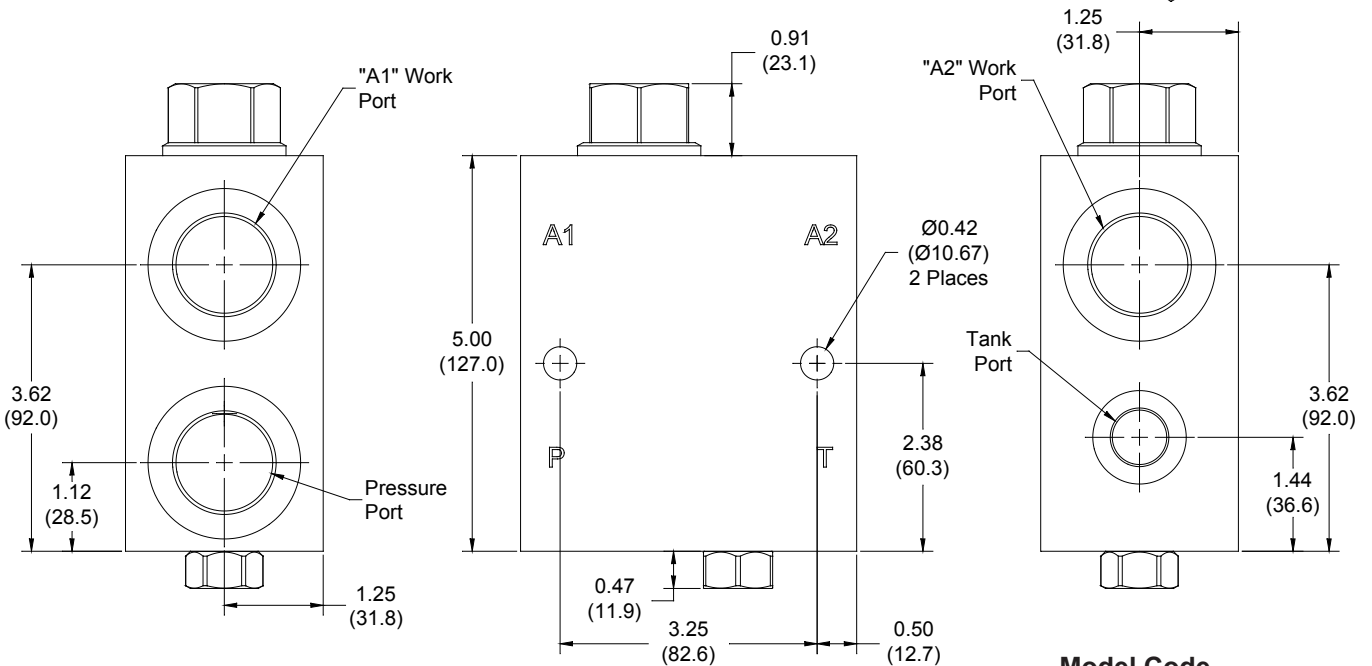
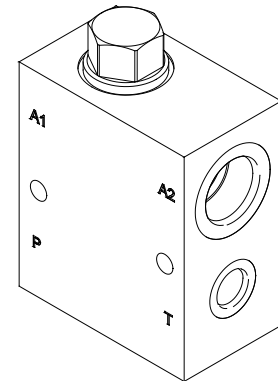
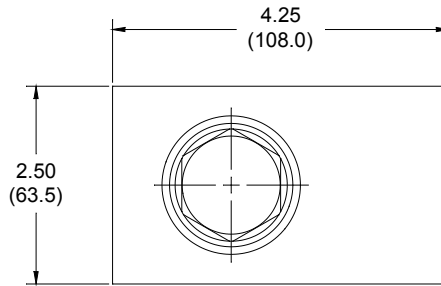
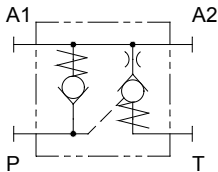

Specifications

Code	Part No.	Pressure Port Size	A1 Port Size	A2 Port Size	Tank Port Size
AD12	621033	-12 SAE	-12 SAE	-12 SAE	-08 SAE
AD16	602151AA	-16 SAE	-16 SAE	-16 SAE	-08 SAE
AD20	611926	-20 SAE	-20 SAE	-20 SAE	-08 SAE

Model Code

Accumulator Dump Valve

AD



Size

Code
12
16
20

Power Unit Accessories

LOW PROFILE AND LITTLE CHAMP® POWER UNITS

Gear Pumps - SAE AA



Dimensions shown in: Inches (± .125)
(millimeters (± 1 mm))

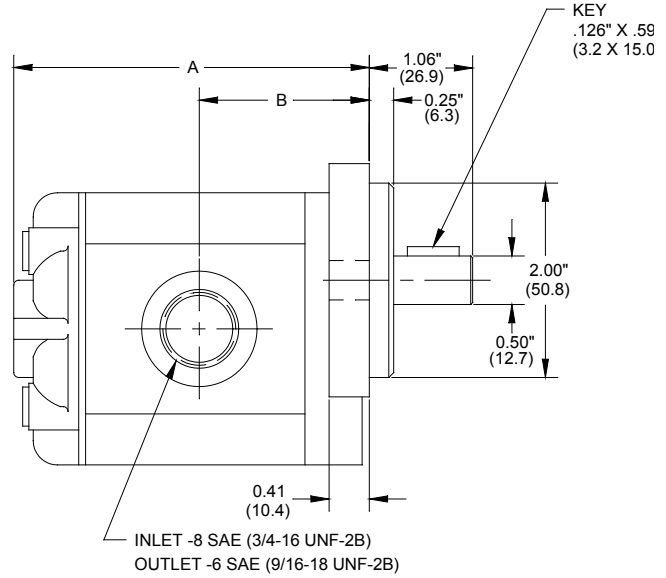
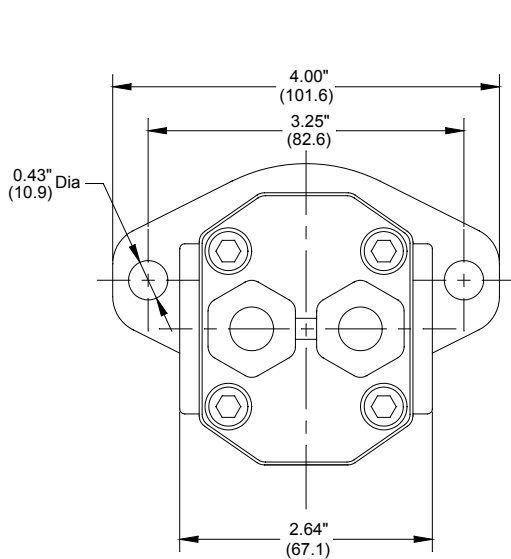

Dimensions

Code	A	B
G0.6B30	3.29 (83.6)	1.56 (39.6)
G0.8B30	3.37 (85.6)	1.60 (40.6)
G1.1B30	3.50 (88.9)	1.65 (41.9)
G1.6B30	3.66 (93.0)	1.75 (44.4)
G2.0B30	3.82 (97.0)	1.81 (46.0)
G2.3B30	3.92 (100.0)	1.87 (47.5)
G3.0B27	4.11 (104.4)	1.97 (50.0)
G3.4B26	4.33 (110.0)	2.09 (53.1)

Model Code



Schematic Symbol

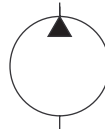

GPM

Code
0.6
0.8
1.1
1.6
2.0
2.3
3.0
3.4

Pressure

Code	Pressure
26	2600 psi (179 bar)
27	2700 psi (186 bar)
30	3000 psi (207 bar)

NOTES:

- Volumetric Efficiency = 93%
Mechanical Efficiency = 90%
Total Efficiency = 83.7%
- No efficiency ratings were used in calculating the gpm of the pumps.

Specifications

Code	Part No.	Cu. in./ (cu. cm)/ Revolution	gpm* (lpm) @ 1725 rpm	Continuous Pressure	Intermittent Pressure	Maximum Speed (rpm)
G0.6B30	610169	.073 (1.20)	.545 (2.1)	3000 psi (207 bar)	3600 psi (248 bar)	4500
G0.8B30	610170	.103 (1.69)	.769 (2.9)	3000 psi (207 bar)	3600 psi (248 bar)	4500
G1.1B30	610171	.152 (2.49)	1.14 (4.3)	3000 psi (207 bar)	3600 psi (248 bar)	4500
G1.6B30	610172	.213 (3.49)	1.59 (6.0)	3000 psi (207 bar)	3300 psi (228 bar)	3500
G2.0B30	610173	.262 (4.29)	1.96 (7.4)	3000 psi (207 bar)	3300 psi (228 bar)	3500
G2.3B30	610174	.305 (5.00)	2.28 (8.6)	3000 psi (207 bar)	3300 psi (228 bar)	3000
G3.0B27	610175	.396 (6.49)	2.96 (11.2)	2700 psi (186 bar)	3150 psi (217 bar)	2500
G3.4B26	610176	.476 (7.80)	3.44 (13.0)	2600 psi (179 bar)	3000 psi (207 bar)	2500

*NOTE: gpm = rpm x Pump Displacement (Cu. in./Rev.)

Power Unit Accessories

LOW PROFILE AND LITTLE CHAMP® POWER UNITS

Gear Pumps - SAE A

Dimensions shown in: Inches (± .125)
millimeters (± 1 mm)

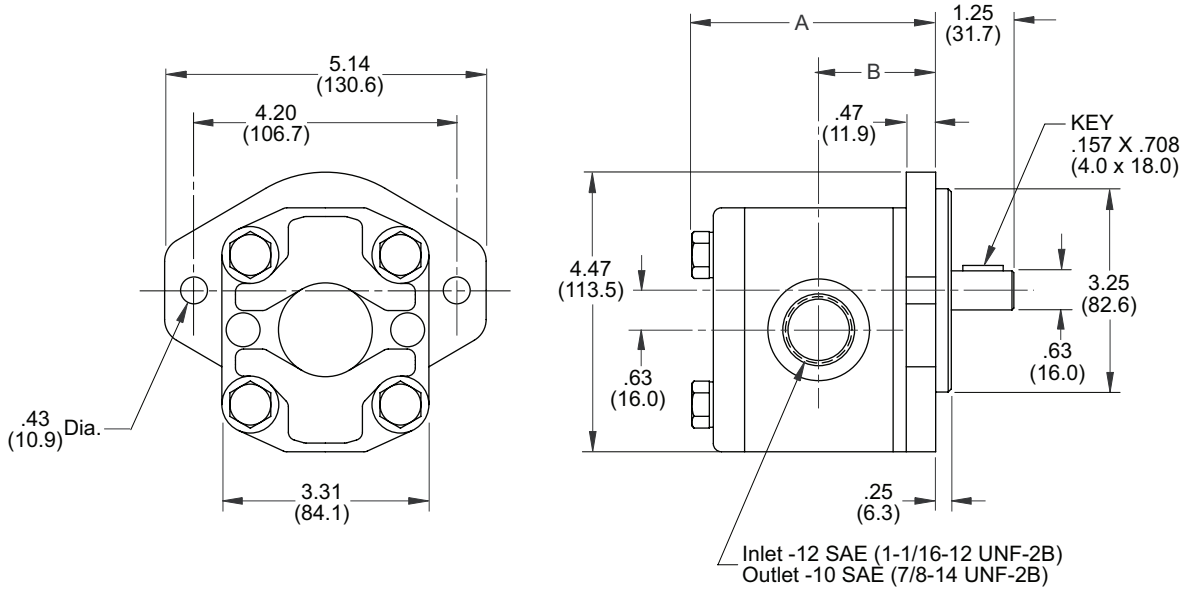

Dimensions

Code	A	B
G2.0B31.5	3.23 (82.0)	1.55 (39.4)
G2.9B31.5	3.23 (82.0)	1.55 (39.4)
G3.8B31.5	3.23 (82.0)	1.55 (39.4)
G5.0B30	3.90 (99.1)	1.87 (47.5)
G6.8B30	3.90 (99.1)	1.87 (47.5)
G8.7B30	4.35 (110.5)	2.11 (53.6)
G10B29	4.53 (115.1)	2.18 (55.4)
G11.8B27	4.53 (115.1)	2.18 (55.4)

Model Code



Schematic Symbol

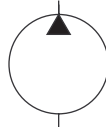

GPM

Code
2.0
2.9
3.8
5.0
6.8
8.7
10
11.8

Pressure

Code	Pressure
27	2700 psi (186 bar)
29	2900 psi (200 bar)
30	3000 psi (207 bar)
31.5	3150 psi (217 bar)

NOTES:

1. Volumetric Efficiency = 93%
Mechanical Efficiency = 90%
Total Efficiency = 83.7%
2. No efficiency ratings were used in calculating the gpm of the pumps.

Specifications

Code	Part No.	Cu. in./ (cu. cm)/ Revolution	gpm* (lpm) @ 1725 rpm	Continuous Pressure	Intermittent Pressure	Maximum Speed (rpm)
G2.0B31.5	610178	.262 (4.29)	1.96 (7.4)	3150 psi (217 bar)	3600 psi (248 bar)	3500
G2.9B31.5	610179	.384 (6.29)	2.87 (10.7)	3150 psi (217 bar)	3600 psi (248 bar)	3500
G3.8B31.5	610180	.506 (8.29)	3.78 (14.3)	3150 psi (217 bar)	3600 psi (248 bar)	3500
G5.0B30	610181	.671 (11.00)	5.01 (19.0)	3000 psi (207 bar)	3300 psi (228 bar)	3500
G6.8B30	610182	.915 (15.00)	6.83 (25.8)	3000 psi (207 bar)	3300 psi (228 bar)	3500
G8.7B30	610183	1.159 (19.00)	8.65 (32.7)	3000 psi (207 bar)	3300 psi (228 bar)	3000
G10B29	610184	1.342 (22.00)	10.02 (37.9)	2900 psi (200 bar)	3150 psi (217 bar)	3000
G11.8B27	610185	1.586 (26.00)	11.84 (44.8)	2700 psi (186 bar)	3000 psi (207 bar)	2500

*NOTE: gpm = rpm x Pump Displacement (Cu. in./Rev.)

Power Unit Accessories

ALL POWER UNITS

Fixed Vane Pumps - SAE A

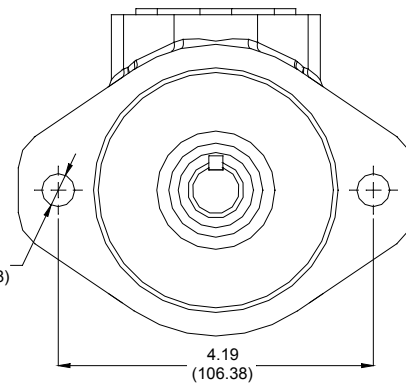
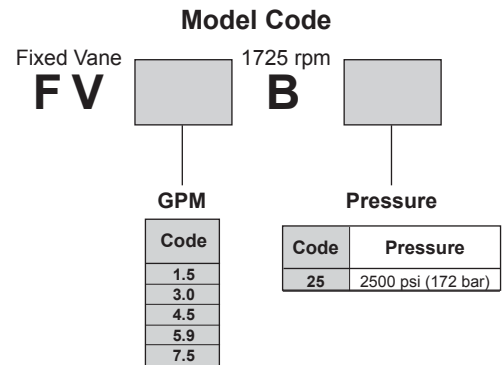
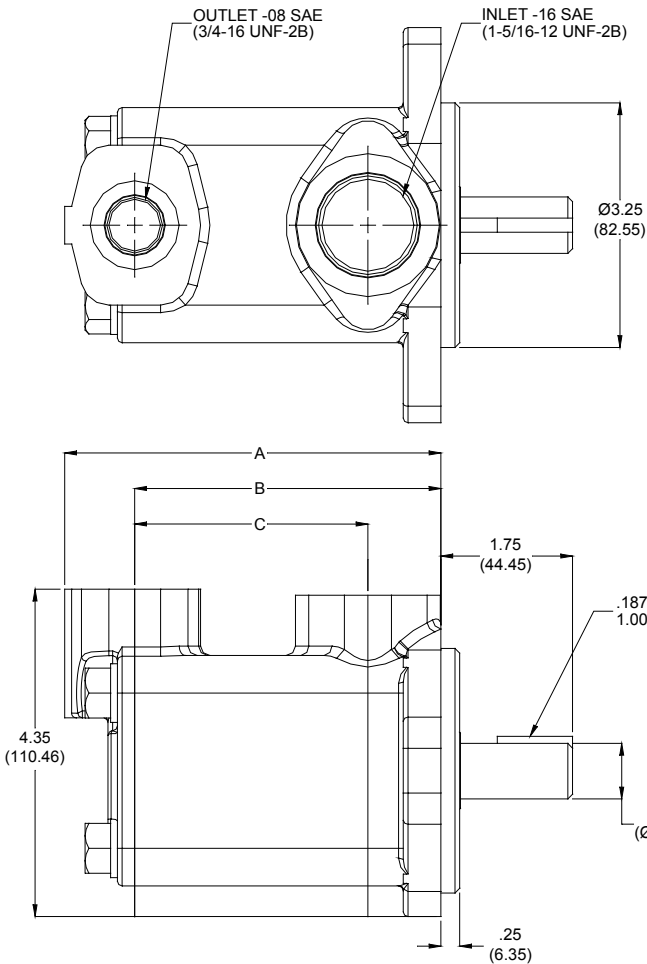

Dimensions

Code	A	B	C
FV1.5B25	4.55 (115.6)	3.62 (91.9)	2.65 (67.3)
FV3.0B25	4.55 (115.6)	3.62 (91.9)	2.65 (67.3)
FV4.5B25	4.55 (115.6)	3.62 (91.9)	2.65 (67.3)
FV5.9B25	4.80 (121.9)	3.87 (98.3)	2.90 (73.7)
FV7.5B25	4.85 (123.2)	3.87 (98.3)	2.90 (73.7)

Schematic Symbol



Specifications

Code	Part No.	Cu. in./ (cu. cm)/ Revolution	gpm* (lpm) @ 1725 rpm	Continuous Pressure	Maximum Speed (rpm)
FV1.5B25	1005530	0.20 (3.3)	1.49 (5.6)	2500 psi (172 bar)	4800
FV3.0B25	604580AA	0.40 (6.6)	2.99 (11.3)	2500 psi (172 bar)	4500
FV4.5B25	1005531	0.60 (9.8)	4.48 (17.0)	2500 psi (172 bar)	4000
FV5.9B25	1005529	0.80 (13.1)	5.97 (22.6)	2500 psi (172 bar)	3400
FV7.5B25	1005532	1.00 (16.4)	7.47 (28.3)	2500 psi (172 bar)	3200

*NOTE: gpm = rpm x Pump Displacement (Cu. in./Rev.)

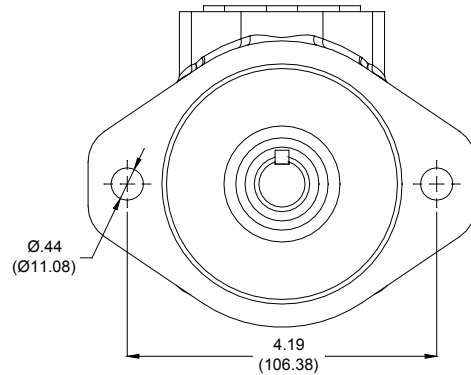
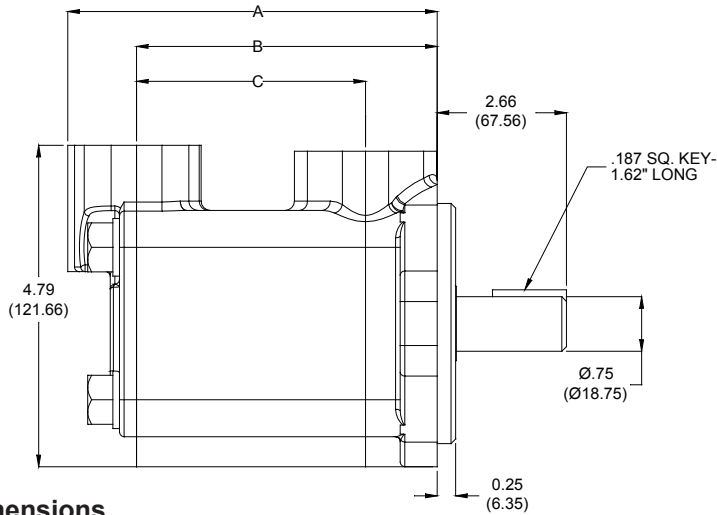
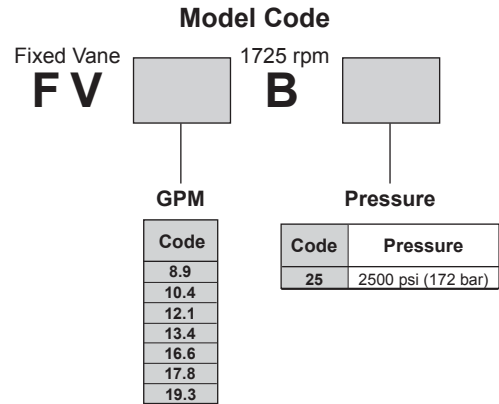
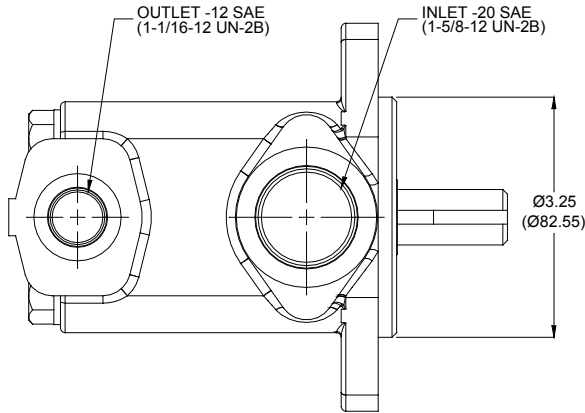

Dimensions

Code	A	B	C
FV8.9B25	4.93 (125.2)	4.02 (102.1)	2.80 (71.1)
FV10.4B25	5.18 (131.6)	4.27 (108.5)	3.05 (77.5)
FV12.1B25	5.18 (131.6)	4.27 (108.5)	3.05 (77.5)
FV13.4B25	5.18 (131.6)	4.27 (108.5)	3.05 (77.5)
FV16.6B25	5.38 (136.7)	4.47 (113.5)	3.25 (82.6)
FV17.8B25	5.52 (140.2)	4.61 (117.1)	3.39 (86.1)
FV19.3B25	5.52 (140.2)	4.61 (117.1)	3.39 (86.1)

Schematic Symbol

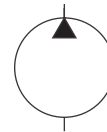

Specifications

Code	Part No.	Cu. in./ (cu. cm/) Revolution	gpm* (lpm) @ 1725 rpm	Continuous Pressure	Maximum Speed (rpm)
FV8.9B25	1005539	1.19 (19.5)	8.89 (33.7)	2500 psi (172 bar)	3400
FV10.4B25	1005540	1.39 (22.8)	10.38 (39.3)	2500 psi (172 bar)	3000
FV12.1B25	1005541	1.62 (26.5)	12.10 (46.5)	2500 psi (172 bar)	2800
FV13.4B25	1005542	1.81 (29.7)	13.44 (50.9)	2500 psi (172 bar)	2800
FV16.6B25	1005543	2.22 (36.4)	16.58 (62.8)	2500 psi (172 bar)	2500
FV17.8B25	615804AC	2.38 (39.0)	17.77 (67.3)	2500 psi (172 bar)	2400
FV19.3B25	611342	2.59 (42.4)	19.34 (73.2)	2500 psi (172 bar)	2400

*NOTE: gpm = rpm x Pump Displacement (Cu. in./Rev.)

Power Unit Accessories

ALL POWER UNITS

Pump Motor Adaptor and Couplings



Pump	Adaptor and Couplings	PVR6, HPV6 PVX8	PVR15, HPV10/15 PVX11/15	HPV20-29, PVX20/29/36	PVX46-75	PVR50	G0.6B30-G3.4B26	G2.0B31.5-G11.8B27	Coupling Series
SAE Shaft Dia.		SAE-A	SAE-B	SAE-C	SAE-D	SAE None	SAE-AA	SAE-A	
		.75 x .19	.87 x .25	1.25 x .31	1.75 x .44	1.50 x .37	.50 x .12	.62 x .16	
.5 - 3 HP 56C .63 x .19	C-Face	902497					974064	902497	PM90
	Motor Cplg	954876					954876	954876	
	Pump Cplg	954846					974140	964294	
	Insert	954855					954855	954855	
1HP-2 HP 143/145TC .87 x .19	C-Face	902497					974064	902497	PM90
	Motor Cplg	954847					954847	954847	
	Pump Cplg	954846					974140	964294	
	Insert	954855					954855	954855	
3HP, 5 HP 182/184TC 1.12 x .25	C-Face	954856	954858			600619	974065	974741	PM90
	Motor Cplg	954849	954849			914091*	954849	954849	
	Pump Cplg	954846	954848			914099*	954860	964294	
	Insert	954874	954874			914217*	954874	954874	
7.5HP, 10 HP 213/215TC 1.37 x .31	C-Face	903606	166719	600616		600620	974066	954856	M200
	Motor Cplg	954850	954850	954850		914095*	954850	954850	
	Pump Cplg	914070	914072	914078		914099*	914064	914066	
	Insert	914216	914216	914216		914217*	914216	914216	
15HP, 20 HP 254/256TC 1.62 x .37	C-Face	148618	166616	934788		904611		903606	M300
	Motor Cplg	954851	954851	954851		954851		954851	
	Pump Cplg	914085	914087	914094		914099		914081	
	Insert	914217	914217	914217		914217		914217	
25HP, 30 HP 284/286TC 1.87 x .50	C-Face		934782	974817	611669	904081			M400
	Motor Cplg		954852	954852	954852	954852			
	Pump Cplg		914004	934254	611625	914112			
	Insert		914218	914218	914218	914218			
40HP, 50 HP 324/326TC 2.12 x .50	C-Face			934791	611670	902778			M500
	Motor Cplg			914134	914134	914134			
	Pump Cplg			914123	914130	914127			
	Insert			914219	914219	914219			
60HP, 75 HP 364/365TC 2.37 x .62	C-Face			934792	611671	934787			M500
	Motor Cplg			954853	954853	954853			
	Pump Cplg			914123	914130	914127			
	Insert			914219	914219	914219			
100 HP 405TC 2.87 x .75	C-Face				611672				M700
	Motor Cplg				610899				
	Pump Cplg				611666				
	Insert				914221				

*NOTE: 300 Series

Description: Power unit design and assembly can be greatly simplified by using pump/motor mounts. Direct mounting flange mount pumps to NEMA “C”-face motors by a pump/motor mount eliminates the need for coupling guard, foot brackets, shims risers and mounting plate. The result is the easiest installation and

most effective method of mounting a pump and motor. Couplings are enclosed in precision machined aluminum mounts to maintain critical alignment. All insert material is made of urethane. Viton and Hytrel material for phosphate ester are also available.

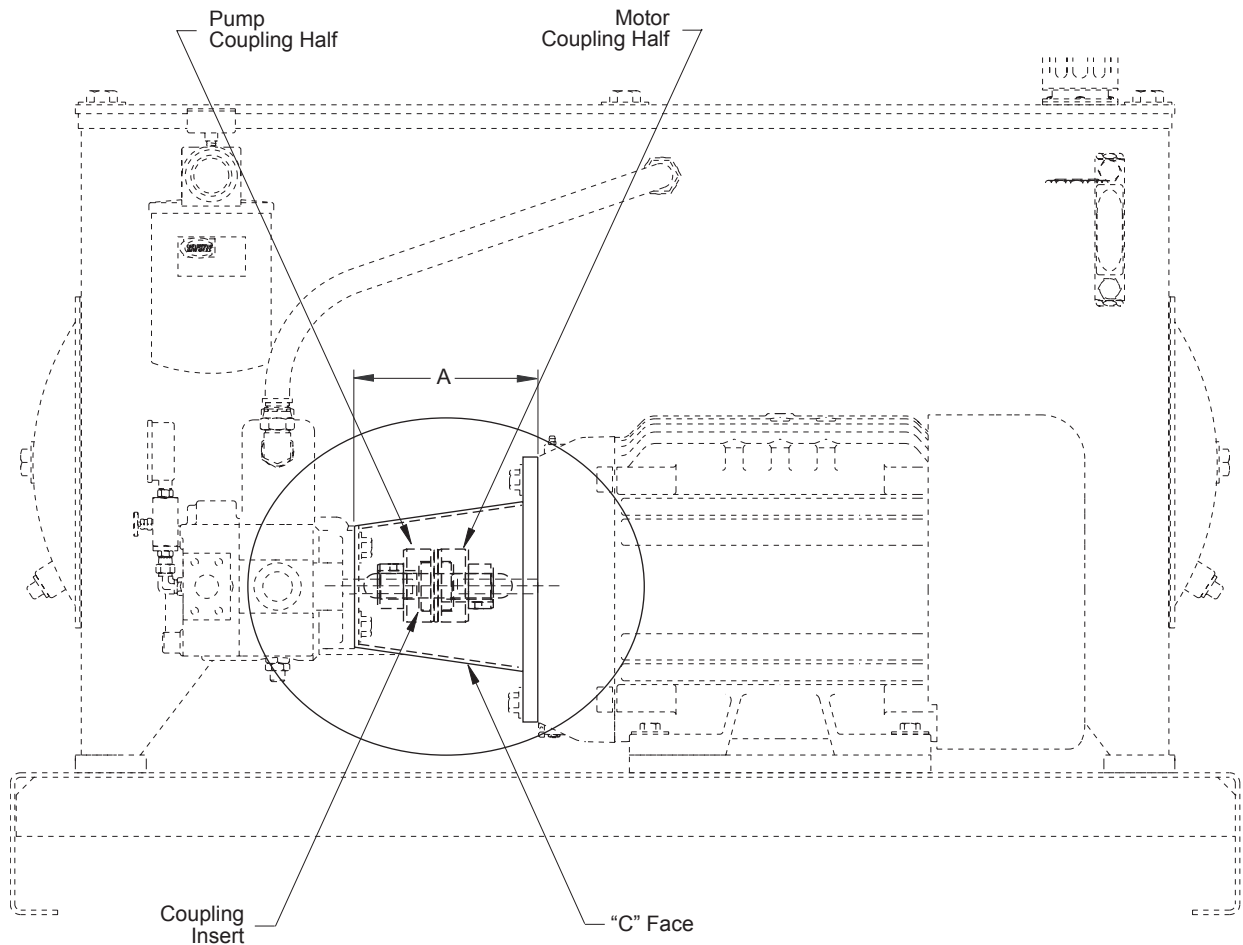

“C” Face Length

Part No.	A	Part No.	A	Part No.	A	Part No.	A
148618	5.88 (149.4)	611669	8.00 (203.2)	904611	7.50 (190.5)	974064	4.25 (107.9)
166616	6.88 (174.8)	611670	9.00 (228.6)	934782	7.50 (190.5)	974065	4.75 (120.6)
166719	5.88 (149.4)	902497	4.25 (107.9)	934788	6.88 (174.8)	974066	5.00 (127.0)
600616	5.88 (149.4)	902778	8.75 (222.2)	934791	7.63 (193.8)	974741	4.75 (120.6)
600619	6.00 (152.4)	903606	5.25 (133.3)	954856	5.00 (127.0)	974817	7.50 (190.5)
600620	6.50 (165.1)	904081	8.25 (209.5)	954858	5.25 (133.3)		

Power Unit Accessories

NFPA/JIC, L-SHAPED AND LOW PROFILE POWER UNITS

Electric Motors

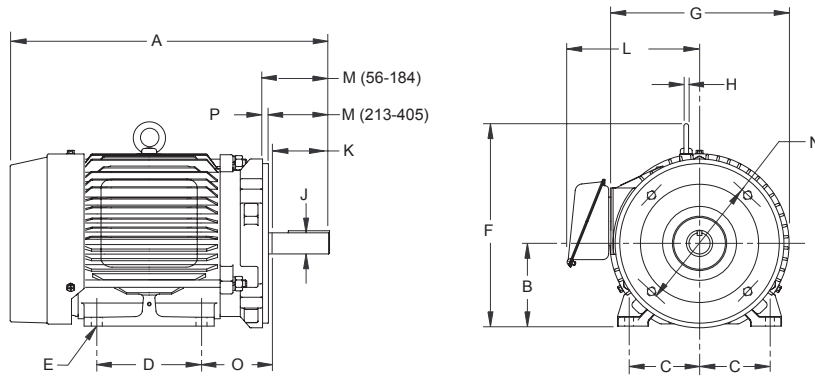

Dimensions shown in: Inches ($\pm .125$)
 (millimeters (± 1 mm))

Dimensions A thru K

Code	A	B	C	D	E Slots	F	G	H	J	K
.5BMTCE	11.35 (288.3)	3.50 (88.9)	2.44 (62.0)	3.00 (76.2)	.34 (8.6)	6.88 (174.8)	6.63 (168.4)	.19 (4.8)	.63 (16.0)	1.88 (47.8)
1BMTCE	12.54 (318.5)		4.00 (101.6)	5.00 (127.0)					.88 (22.4)	2.25 (57.1)
1.5BMTCE			2.75 (69.8)						5.00 (127.0)	2.25 (57.1)
2BMTCE	14.43 (366.5)	4.50 (114.3)	3.75 (95.2)	4.50 (114.3)	.41 (10.4)	8.69 (220.7)	7.88 (200.2)	.25 (6.3)	1.13 (28.7)	2.75 (69.8)
3BMTCE				5.50 (139.7)						
5BMTCE	15.42 (391.7)	5.25 (133.3)	4.25 (107.9)	7.00 (177.8)	.53 (13.5)	10.25 (260.3)	9.56 (242.8)	.31 (7.9)	1.38 (35.1)	3.38 (85.9)
7.5BMTCE	8.25 (209.5)									
10BMTCE	10.00 (254.0)									
15BMTCF	23.40 (594.4)	6.25 (158.7)	5.00 (127.0)	9.50 (241.3)	.53 (13.5)	12.88 (327.2)	12.94 (328.7)	.38 (9.7)	1.63 (41.4)	4.00 (101.6)
20BMTCF	11.00 (279.4)									
25BMTCF	26.90 (683.3)	7.00 (177.8)	5.50 (139.7)	12.00 (304.8)	.66 (16.8)	15.63 (397.0)	14.63 (371.6)	.50 (12.7)	1.88 (47.8)	4.63 (117.6)
30BMTCF	10.50 (266.7)									
40BMTCF	11.25 (285.7)									
50BMTCF	30.44 (773.2)	8.00 (203.2)	6.25 (158.7)	12.25 (311.1)	.66 (16.8)	16.50 (419.1)	16.50 (419.1)	.63 (16.0)	2.38 (60.5)	5.88 (149.4)
60BMTCF	11.25 (285.7)									
75BMTCF	33.44 (849.3)	9.00 (228.6)	7.00 (177.8)	13.75 (349.2)	.81 (20.6)	20.31 (515.9)	20.13 (511.3)	.75 (19.0)	2.88 (73.2)	7.25 (184.1)
100BMTCF	12.25 (311.1)									
125BMTCF	44.62 (1133.3)	11.00 (279.4)	9.00 (228.6)	14.50 (368.3)	.81 (20.6)	23.38 (593.9)	25.25 (641.3)	.88 (22.4)	3.38 (85.9)	8.50 (215.9)

Dimensions L thru P

Code	L	M	N	O	P
.5BMTCE	5.00 (127.0)	2.06 (52.3)	5.88 (149.4)	2.75 (69.8)	.13 (3.3)
1BMTCE	5.25 (133.3)	2.13 (54.1)			
1.5BMTCE					
2BMTCE	5.88 (149.4)	2.63 (66.8)	7.25 (184.1)	4.25 (107.9)	.25 (6.3)
3BMTCE					
5BMTCE	7.38 (187.5)	3.13 (79.5)	4.75 (120.6)		
7.5BMTCE					
10BMTCE	9.63 (244.6)	3.75 (95.2)	9.00 (228.6)		
15BMTCF					
20BMTCF	13.13 (333.5)	4.38 (111.3)	11.00 (279.4)	5.88 (149.4)	
25BMTCF					
30BMTCF	14.13 (358.9)	5.00 (127.0)	5.25 (133.3)		
40BMTCF					
50BMTCF	15.06 (382.5)	5.63 (143.0)	5.88 (149.4)		
60BMTCF					
75BMTCF	18.00 (457.2)	7.00 (177.8)	6.63 (168.4)		
100BMTCF					
125BMTCF	23.38 (593.9)	8.25 (209.5)	14.00 (355.6)	7.50 (190.5)	

Schematic Symbol





Power Unit Accessories

NFPA/JIC, L-SHAPED AND LOW PROFILE POWER UNITS

Electric Motors - Specifications

Dimensions shown in: Inches (± .125)
 (millimeters (± 1 mm))

Specifications

Code	Part No.	Motor Frame	Voltage	RPM	Enclosure	Service Factor	Full Load Amps	Shipping Weight
.5BMTCE	601042	56C	208-230V, 460V 60 Hz, 3 Phase	1725	TEFC	1.25	2.1 - 2/1	23 lbs. (10.4 kg)
1BMTCE	148708	143TC				3.2 - 2.8/1.4	38 lbs. (17.2 kg)	
1.5BMTCE	148709	145TC				4.5 - 4.2/2.1	42 lbs. (19.1 kg)	
2BMTCE	148710	145TC				6 - 5.6/2.8	46 lbs. (20.9 kg)	
3BMTCE	148681	182TC				8.3 - 8.2/4.1	78 lbs. (35.4 kg)	
5BMTCE	148682	184TC				13.8 - 13.4/6.7	81 lbs. (36.7 kg)	
7.5BMTCE	148683	213TC				21.4 - 20.4/10.2	129 lbs. (58.5 kg)	
10BMTCE	148684	215TC				28.5 - 28.4/14.2	141 lbs. (64.0 kg)	
15BMTCF	148685	254TC				38.8/19.4	253 lbs. (114.8 kg)	
20BMTCF	148686	256TC				48/24	276 lbs. (125.2 kg)	
25BMTCF	954900	284TC				60/30	401 lbs. (181.9 kg)	
30BMTCF	902588	286TC				72/36	412 lbs. (186.9 kg)	
40BMTCF	902162	324TC				94/47	594 lbs. (269.4 kg)	
50BMTCF	600026	326TC				118/59	579 lbs. (262.6 kg)	
60BMTCF	954906	364TC	140/70	768 lbs. (348.4 kg)				
75BMTCF	954908	365TC	172/86	808 lbs. (366.5 kg)				
100BMTCF	601584	405TC	230/115	1121 lbs. (508.5 kg)				
125BMTCF	610375	444TC	312/156	1540 lbs. (698.5 kg)				

Power Unit Accessories

LITTLE CHAMP® POWER UNITS

Electric Motors



Dimensions shown in: Inches (± .125)
(millimeters (± 1 mm))

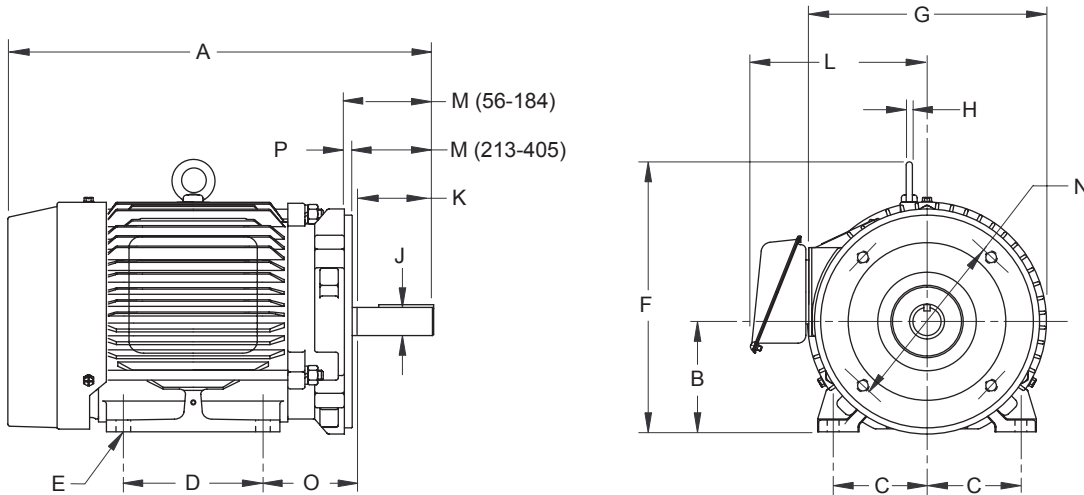

Dimensions A thru K

Code	A	B	C	D	E Slots	F	G	H	J	K
005T	11.48 (289.1)	N/A	N/A	N/A	N/A	N/A	6.63 (168.4)	.19 (4.8)	.63 (16.0)	1.88 (47.8)
007T										
010T										
015T	12.48 (317.0)									
020T	13.54 (343.9)									
030T	14.12 (358.6)									
050T	17.12 (434.8)						7.88 (200.2)	.25 (6.3)	1.13 (28.7)	2.75 (69.8)
075T	20.12 (511.0)	9.56 (242.8)	.31 (7.9)	1.38 (35.1)	3.38 (85.9)					
100T	20.12 (511.0)									

Dimensions L thru P

Code	L	M	N	O	P
005T	5.00 (127.0)	2.06 (52.3)	5.88 (149.4)	N/A	.13 (3.3)
007T					
010T					
015T					
020T					
030T					
050T	5.88 (149.4)	2.63 (66.8)	7.25 (184.1)		4.25 (107.9)
075T	7.38 (187.5)	3.13 (79.5)			
100T					

Schematic Symbol





Power Unit Accessories

LITTLE CHAMP® POWER UNITS

Electric Motors - Specifications

Dimensions shown in: Inches (± .125)
 (millimeters (± 1 mm))

Specifications

Code	Part No.	Motor Frame	Voltage	RPM	Enclosure	Service Factor	Full Load Amps	Shipping Weight
005T	974035	56C	208-230V, 460V 60 Hz, 3 PHASE	1725	TEFC	1.25	2.1 - 2/1	22 lbs. (10.0 kg)
007T	974036	56C					3.2 - 3/1.5	25 lbs. (11.3 kg)
010T	601352	56C				1.15	3.7 - 3.4/1.7	30 lbs. (13.6 kg)
015T	974038	56C					5.3 - 5/2.5	34 lbs. (15.4 kg)
020T	601353	56C					6.5 - 6.2/3.1	41 lbs. (18.6 kg)
030T	601351	56C					8.5 - 8.2/4.1	49 lbs. (22.2 kg)
050T	904684	184TC					15 - 13.2/6.6	75 lbs. (34.0 kg)
075T	904685	213TC					21.5 - 20/10	113 lbs. (51.3 kg)
100T	974368	215TC				1.00	28 - 26/13	128 lbs. (58.1 kg)

Power Unit Accessories

NFPA/JIC AND L-SHAPED POWER UNITS

Motor Starters



Dimensions shown in: Inches (± .125)
 (millimeters (± 1 mm))

Description: Motor Starters are designed to meet our interpretation of the N.E.C. code. If motor or any starter components are replaced with other than original components, compliance with the N.E.C. code may be voided. Motor Starter overloads can be adjusted and reset. Standard features include:

- 1 - 50 H.P. (.75 - 37.3 kW) Full Voltage Non-Reversing
- Voltages 208, 230, 460
- Three Phase
- I.E.C. Style Components
- Lighted Green Start Button
- Mushroom Style Red Stop Button
- NEMA 12 Enclosure
- Starters Mounted, Wired and Fully Tested

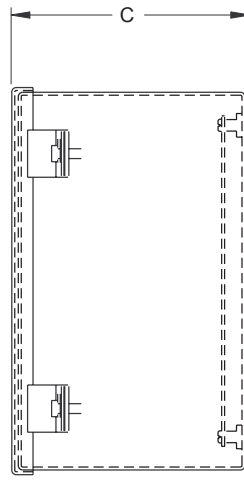
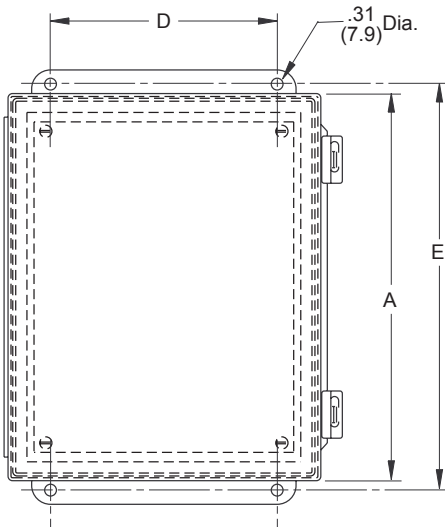
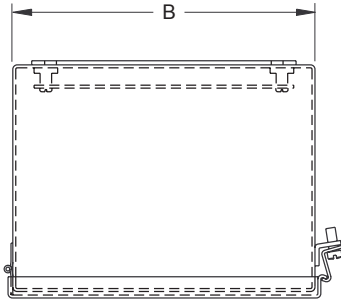

Dimensions

Horsepower	Voltage	A	B	C	D	E
1 - 10 (.75 - 7.5 kW)	208	10.00 (254.0)	8.00 (203.2)	6.00 (152.4)	6.00 (152.4)	10.75 (273.0)
1 - 10 (.75 - 7.5 kW)	230	10.00 (254.0)	8.00 (203.2)	6.00 (152.4)	6.00 (152.4)	10.75 (273.0)
1 - 20 (.75 - 14.9 kW)	460	10.00 (254.0)	8.00 (203.2)	6.00 (152.4)	6.00 (152.4)	10.75 (273.0)
15 - 20 (11.2 - 14.9 kW)	230	12.00 (304.8)	12.00 (304.8)	6.00 (152.4)	6.00 (152.4)	12.75 (323.8)
25 - 40 (18.6 - 29.8 kW)	460	12.00 (304.8)	12.00 (304.8)	6.00 (152.4)	6.00 (152.4)	12.75 (323.8)
25 - 30 (18.6 - 22.4 kW)	230	16.00 (406.4)	14.00 (355.6)	8.00 (203.2)	12.00 (304.8)	16.75 (425.4)
40 - 50 (29.8 - 37.3 kW)	230	30.00 (762.0)	20.00 (508.0)	9.00 (228.6)	18.00 (457.2)	30.75 (781.0)
50 (37.3 kW)	460	30.00 (762.0)	20.00 (508.0)	9.00 (228.6)	18.00 (457.2)	30.75 (781.0)